

## UNIVERSAL TYPE - FLOOR / CEILING / WALL

# SPLIT TYPE AIR CONDITIONER

## IMPORTANT!

### Please Read Before Starting

This air conditioning system meets strict safety and operating standards. As the installer or service person, it is an important part of your job to install or service the system so it operates safely and efficiently.

#### For safe installation and trouble-free operation, you must:

- Carefully read this instruction booklet before beginning.
- Follow each installation or repair step exactly as shown.
- Observe all local, state, and national electrical codes.
- Pay close attention to all danger, warning, and caution notices given in this instruction sheet.

**WARNING :** This symbol refers to a hazard or unsafe practice which can result in severe personal injury or death.

**CAUTION :** This symbol refers to a hazard or unsafe practice which can result in personal injury and the potential for product or property damage.

- Hazard alerting symbols



Electrical



Safety/alert

#### If Necessary, Get Help

These instructions are all you need for most installation sites and maintenance conditions. If you require help for a special problem, contact our sales/service outlet or your certified dealer for additional instructions.

#### In Case of Improper Installation

The manufacturer shall in no way be responsible for improper installation or maintenance service, including failure to follow the instructions in this document.

## SPECIAL PRECAUTIONS

### When Wiring

**ELECTRICAL SHOCK CAN CAUSE SEVERE PERSONAL INJURY OR DEATH. ONLY A QUALIFIED, EXPERIENCED ELECTRICIAN SHOULD ATTEMPT TO WIRE THIS SYSTEM.**

- Do not supply power to the unit until all wiring and tubing are completed or reconnected and checked.
- Highly dangerous electrical voltages are used in this system. Carefully refer to the wiring diagram and these instructions when wiring. Improper connections and inadequate grounding can cause **accidental injury or death**.

- **Ground the unit** following local electrical codes.
- Connect all wiring tightly. Loose wiring may cause overheating at connection points and a possible fire hazard.

### When Transporting

Be careful when picking up and moving the indoor and outdoor units. Get a partner to help, and bend your knees when lifting to reduce strain on your back. Sharp edges or thin aluminum fins on the air conditioner can cut your fingers.

### When Installing...

#### ...In a Ceiling or Wall

Make sure the ceiling/wall is strong enough to hold the unit's weight. It may be necessary to construct a strong wood or metal frame to provide added support.

#### ...In a Room

Properly insulate any tubing run inside a room to prevent "sweating" that can cause dripping and water damage to walls and floors.

#### ...In Moist or Uneven Locations

Use a raised concrete pad or concrete blocks to provide a solid, level foundation for the outdoor unit. This prevents water damage and abnormal vibration.

#### ...In an Area with High Winds

Securely anchor the outdoor unit down with bolts and a metal frame. Provide a suitable air baffle.

#### ...In a Snowy Area (for Heat Pump-type Systems)

Install the outdoor unit on a raised platform that is higher than drifting snow. Provide snow vents.

### When Connecting Refrigerant Tubing

- Keep all tubing runs as short as possible.
- Use the flare method for connecting tubing.
- Apply refrigerant lubricant to the matching surfaces of the flare and union tubes before connecting them, then tighten the nut with a torque wrench for a leak-free connection.
- Check carefully for leaks before starting the test run.

### NOTE:

Depending on the system type, liquid and gas lines may be either narrow or wide. Therefore, to avoid confusion the refrigerant tubing for your particular model is specified as either "small" or "large" rather than as "liquid" or "gas".

### When Servicing

- Turn the power OFF at the main circuit breaker panel before opening the unit to check or repair electrical parts and wiring.
- Keep your fingers and clothing away from any moving parts.
- Clean up the site after you finish, remembering to check that no metal scraps or bits of wiring have been left inside the unit being serviced.
- After installation, explain correct operation to the customer, using the operating manual.

Fig. 1-A

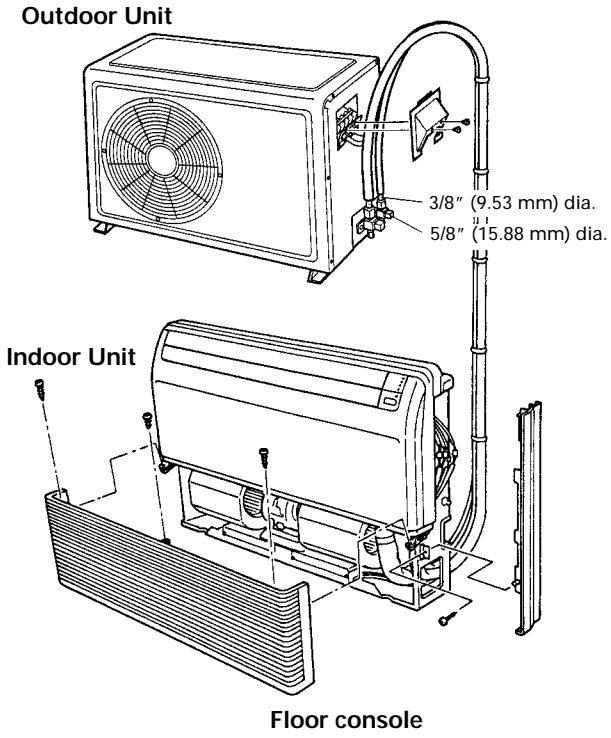
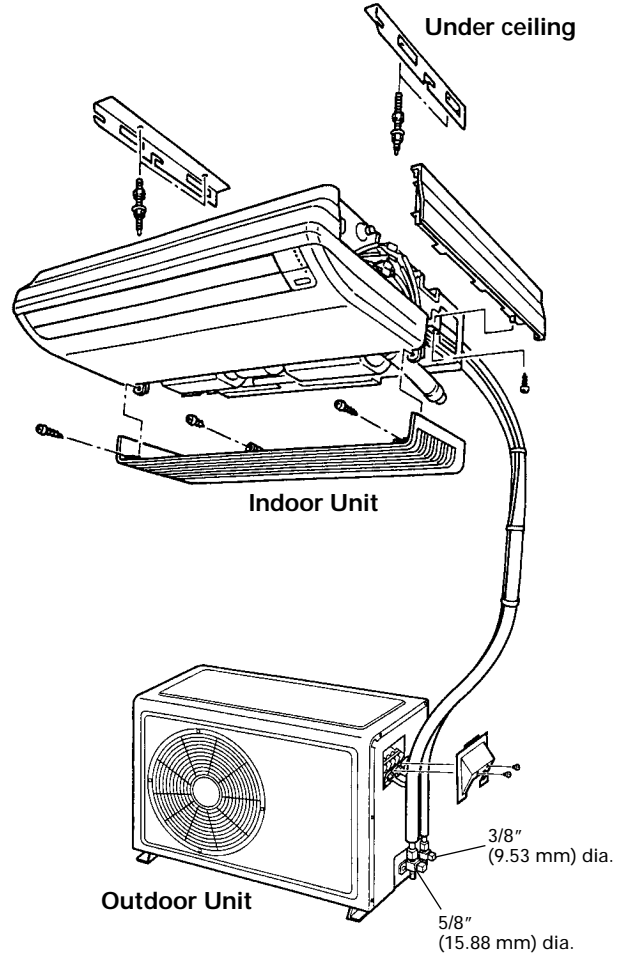

Fig. 1-B



# GENERAL

This INSTALLATION INSTRUCTION SHEET briefly outlines where and how to install the air conditioning system. Please read over the entire set of instructions for the indoor and outdoor units and make sure all accessory parts listed are with the system before beginning.

## 1. TYPE OF COPPER PIPE AND INSULATION MATERIAL

Copper tubing for connecting the outdoor unit to the indoor unit and insulation material is available for purchase locally. When you purchase them, please specify the following.

- (1) Deoxidized annealed copper pipe for refrigerant piping as:

**Table 1**

	Outer diameter	Thickness
Small pipe	3/8" (9.52 mm)	1/32" (0.8 mm)
Large pipe	5/8" (15.88 mm)	3/64" (1.0 mm)

Cut each pipe to the appropriate length +12" (30 cm) to 16" (40 cm) to dampen vibration between units.

### CAUTION

- (1) Limit the height difference between the indoor and outdoor units to within 26 ft. (8 m).
- (2) The maximum length of the piping is 66 ft. (20 m). If the units are further apart than this, correct operation can not be guaranteed.

- (2) Foamed polyethylene insulation for copper pipes as required to precise length of piping. Wall thickness of the insulation should not be less than 5/16" (8 mm).
- (3) Use insulated copper wire for field wiring.

### CAUTION

Check local electrical codes and regulations before obtaining wire. Also, check any specified instructions or limitations.

## 2. ADDITIONAL MATERIALS REQUIRED FOR INSTALLATION

- (1) Refrigeration (armored) tape
- (2) Insulated staples or clamps for connecting wire (See your local electrical codes.)
- (3) Putty
- (4) Refrigeration lubricant
- (5) Clamps or saddles to secure refrigerant piping

## 3. OPERATING RANGE

**Table 2**

	Temperature	Indoor air intake	Outdoor air intake
Cooling	Maximum	90°F DB, 73°F WB	115°F DB
	Minimum	65°F DB, 57°F WB	70° F DB

## ELECTRICAL REQUIREMENT

Always make the air conditioner power supply a special branch circuit and provide a special switch and receptacle. Do not extend the power cord.











### CAUTION

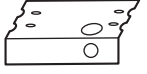
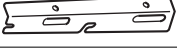
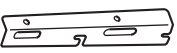
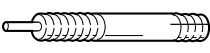

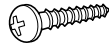
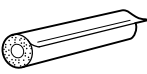

MINIMUM CIRCUIT AMPACITY 15A  
 MAXIMUM OVERCURRENT PROTECTION 20A  
 (TIME DELAY FUSE OR HACR TYPE CIRCUIT BREAKER)

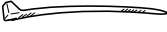
## STANDARD PARTS

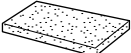
The following installation parts are furnished. Use them as required.

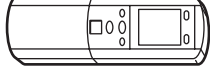
### INDOOR UNIT ACCESSORIES

Name and Shape	Q'ty	Application	
Cover plate (left) 	1		
Cover plate (right) 	1		
Tapping screw (ø4 x 10) 	2		
Installation template 	1	For positioning the indoor unit For under ceiling type.	
Bracket (left) 	1	For suspending the indoor unit from ceiling	
Bracket (right) 	1		
Anchor bolt (M12) 	4		
Spring washer 	4		
Spring nut 	4		
Wall bracket 	2		For suspending the indoor unit on the wall.
Tapping screw (ø4 x 20) 	6		For fixing the wall bracket.
Coupler heat insulator (large) 	1	For indoor side pipe joint (Large pipe)	
Coupler heat insulator (small) 	1	For indoor side pipe joint (small pipe)	
Nylon fastener 	1	For fixing the drain hose	
Drain hose 	1		
Insulation (drain hose) 	1	Adhesive type 70 x 230	

Name and Shape	Q'ty	Application
VT wire 	1	For fixing the drain hose L 280 mm
Remote control unit 	1	Use for air conditioner operation
Battery (penlight) 	4	For remote control unit
Remote control unit holder 	1	For mounting the remote control unit
Tapping screw (ø3 x 12) 	2	For remote control unit holder installation

### OUTDOOR UNIT ACCESSORIES

Name and Shape	Q'ty	Application
Hexagon wrench 	1	For air purge

### OPTIONAL PARTS FOR INDOOR UNIT

Name and Shape	Part No.	Application
Joint pipe-A 	9302812021	For indoor side pipe joint

## SELECTING THE MOUNTING POSITION

### ⚠ WARNING

Install at a place that can withstand the weight of the indoor and outdoor units and install positively so that the units will not topple or fall.

### ⚠ CAUTION

- (1) Do not install where there is the danger of combustible gas leakage.
- (2) Do not install near heat sources.
- (3) If children under 10 years old may approach the unit, take preventive measures so that they cannot reach the unit.

Decide the mounting position with the customer as follows:

### 1. INDOOR UNIT

- (1) Install the indoor unit level on a strong wall, floor, ceiling which is not subject to vibration.
- (2) The inlet and outlet ports should not be obstructed : the air should be able to blow all over the room.
- (3) Install the unit near an electric outlet or special branch circuit.
- (4) Do not install the unit where it will be exposed to direct sunlight.
- (5) Install the unit where connection to the outdoor unit is easy.
- (6) Install the unit where the drain pipe can be easily installed.
- (7) Take servicing, etc. into consideration and leave the spaces shown in Fig.2. Also install the unit where the filter can be removed.

Fig. 2

#### • Floor console

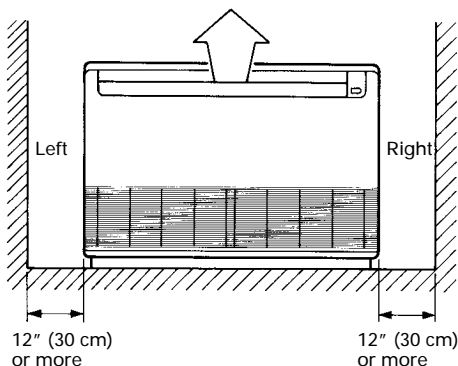

#### • Under ceiling

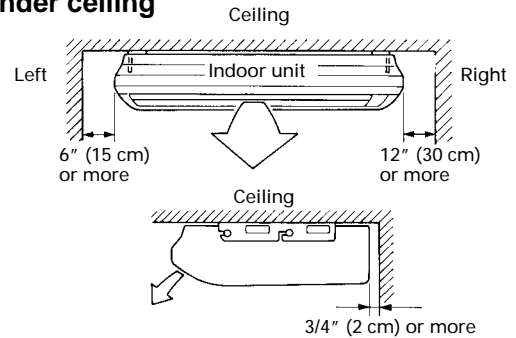

### 2. OUTDOOR UNIT

### ⚠ WARNING

- (1) Install the unit where it will not be tilted by more than 5°
- (2) When installing the outdoor unit where it may be exposed to strong wind, fasten it securely.

- (1) If possible, do not install the unit where it will be exposed to direct sunlight. (If necessary, install a blind that does not interfere with the air flow.)
- (2) Install the outdoor unit in a place where it will be free from being dirty or getting wet by rain as much as possible.
- (3) Install the unit when connection to the indoor unit is easy.
- (4) Do not place animals and plants in the path of the warm air.
- (5) Take the air conditioner weight into account and select a place where noise and vibration are small.
- (6) Select a place so that the warm air and noise from the air conditioner do not disturb neighbors.
- (7) Provide the space shown in Fig. 3 so that the air flow is not blocked. Also for efficient operation, leave open three of the four directions front, rear and both sides.

Fig. 3

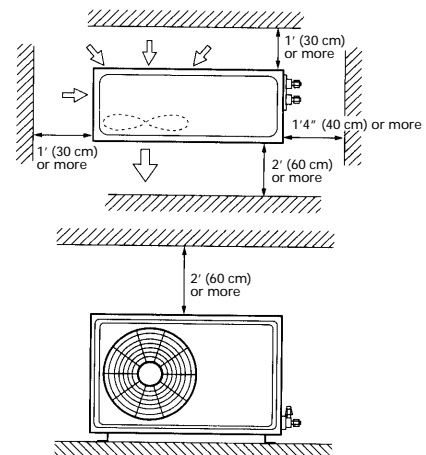

# INSTALLATION PROCEDURE

Install the room air conditioner as follows:

## 1. PREPARING INDOOR UNIT INSTALLATION

### 1. REMOVE THE INTAKE GRILLE

Open the intake grille and remove the three screws. (Fig. 4)

Fig. 4

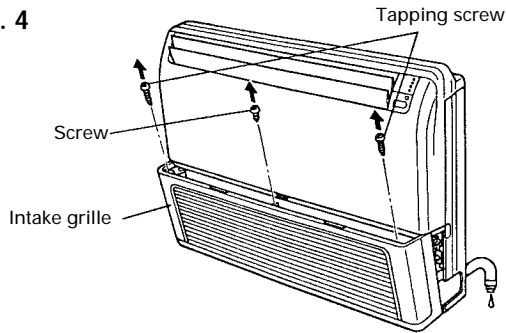

**Remark :** The main unit can be wired before the indoor unit is installed. Select the most appropriate installation order.

## 2. INDOOR UNIT INSTALLATION

### A. FLOOR CONSOLE TYPE

#### 1. DRILLING FOR PIPING

Select piping and drain directions. (Fig. 5)

The piping and drain can be made in three directions as shown below.

Fig. 5

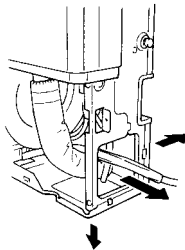

The drain hose can be connected to either the left or right side. (Fig. 6)

Fig. 6

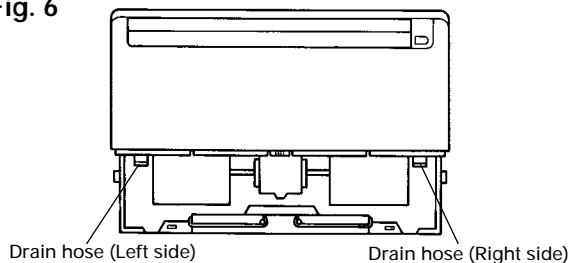

When the directions are selected, drill a 4" (10cm) dia. hole on the wall so that the hole is tilted downward toward the outdoor for smooth water flow. When the pipe is led out from the rear, make a hole in Fig. 7, at the position shown.

Fig. 7

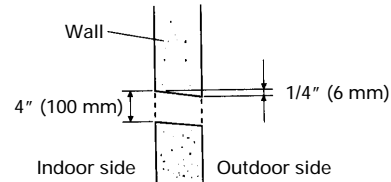

### ⚠ WARNING

**Avoid areas where electrical wiring or conduits are located.**

**Accidentally cutting a live wire can cause death or injury.**

When installing the set to wall, install the accessory wall bracket at the position shown in Fig. 8, and mount the set to it.

Fig. 8

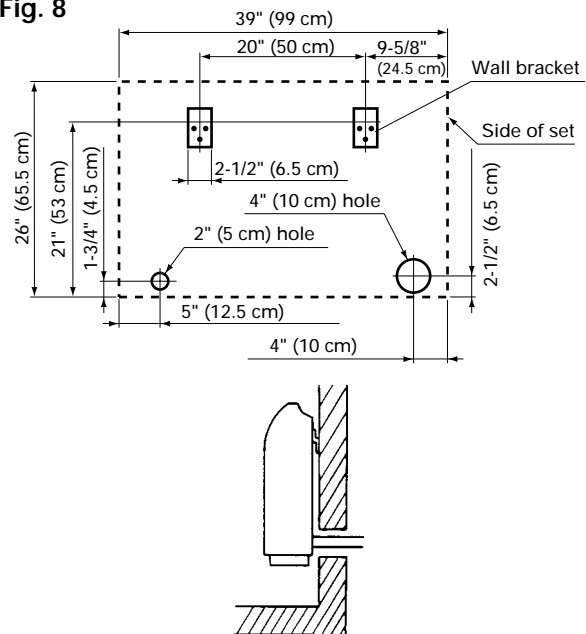

### 2. INSTALLING DRAIN HOSE

#### INSTALL THE DRAIN HOSE

Select whether the drain hose will be connected to the left or right side. (Fig. 6)

Insert the drain hose into drain pan, then secure the drain hose with a nylon fastener. (Fig. 9)

Fig. 9

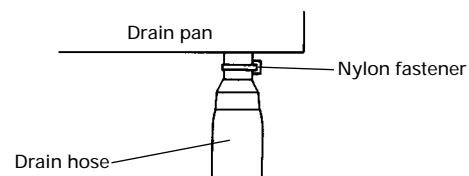

Wrap the insulation(drain hose)around the drain hose connection. (Fig. 10)

Fig. 10

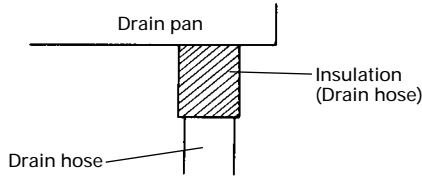

Be sure to arrange the drain hose so that it is leveled lower than the drain hose connecting port of the indoor unit.

Fig. 11

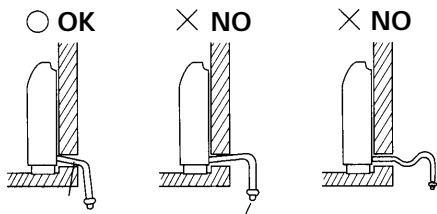

Arrange the drain hose lower than this portion

Drain hose

**CAUTION**

Do not install the unit so that the drain hose side is too high. Height A should be less than 5 mm. (Fig. 12)

Fig. 12

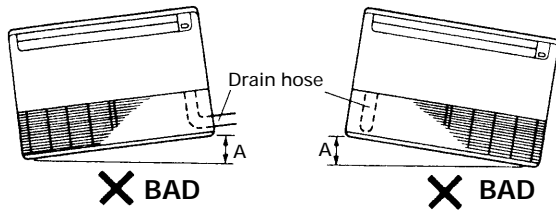

**B. UNDER CEILING TYPE**

Using the installation template, drill holes for piping and anchor bolts(for holes). (Fig. 13)

Fig.13

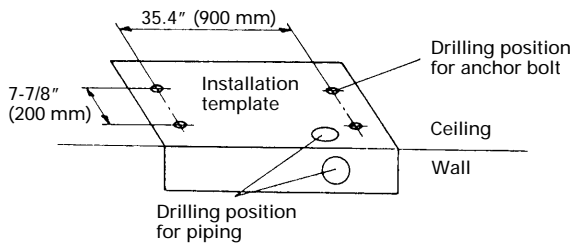

**1. DRILLING FOR PIPING**

Select piping and drain directions. (Fig.14)

Fig. 14

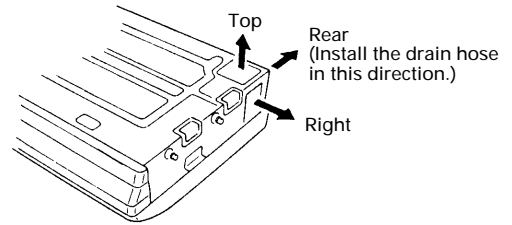

**CAUTION**

Install the drain hose at the rear; it should not be installed on the top or right side.

When the directions are selected, drill 3-1/8" (80 mm) and 2" (50 mm) or 6" (150 mm) dia. hole on the wall so that the hole is tilted downward toward the outdoor for smooth water flow.

Fig. 15

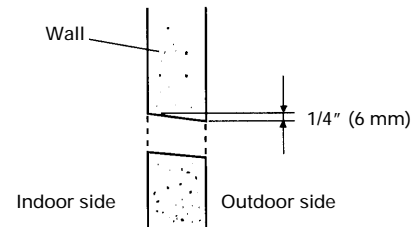

**2. DRILLING HOLES FOR ANCHOR BOLTS AND INSTALLING THE ANCHOR BOLTS.**

With a concrete drill, drill four 1/2" (12.7 mm) dia holes. (Fig. 16)

Fig. 16

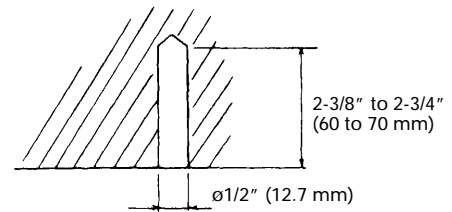

Insert the anchor bolts into the drilled holes, and drive the pins completely into the anchor bolts with a hammer. (Fig. 17)

Fig. 17

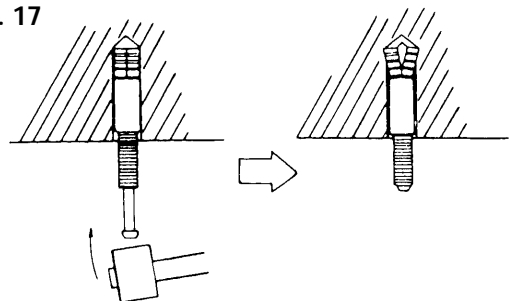

### 3. INSTALLING BRACKETS

Install the brackets with nuts, washers and spring washers. (Fig. 18)

Fig. 18

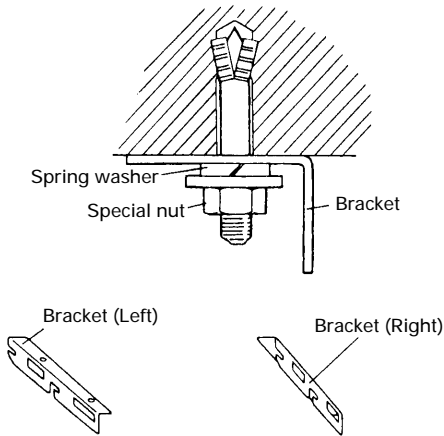

### 4. INSTALLING INDOOR UNIT

Reset the hex bolts as shown in Fig.19.

Fig. 19

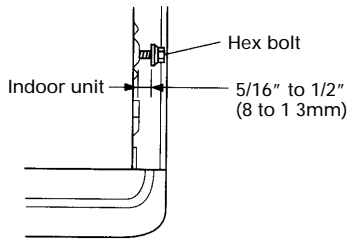

Apply the indoor unit to the brackets.(Fig. 20)

Fig. 20

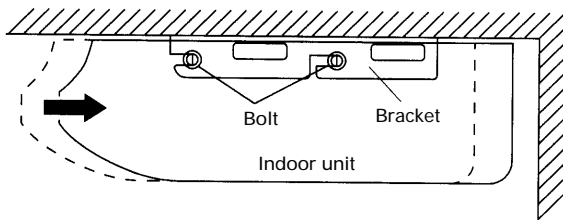

Now, securely tighten the hex bolts in both sides.

### 5. INSTALL THE DRAIN HOSE

Select whether the drain hose will be connected to the left or right side. (Fig. 6)

Insert the drain hose into the drain pan, then secure the drain hose with a nylon fastener. (Fig. 9)

Wrap the insulation (drain hose) around the drain hose connection. (Fig. 10)

Be sure to arrange the drain hose so that it is leveled lower than the drain hose connecting port to the indoor unit. (Fig. 21)

Fig. 21

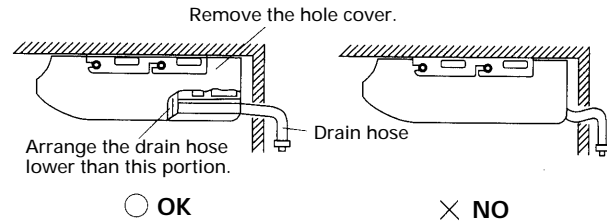

When drain hose is arranged backward. Secure the drain hose with the VT wire. (Fig. 22)

Fig. 22

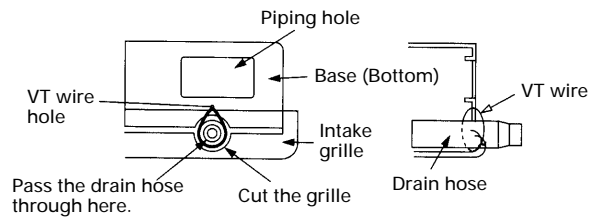

### 3. OUTDOOR UNIT INSTALLATION

- When the outdoor unit will be exposed to strong wind, fasten it with bolts at the places indicated by the arrows. (Fig. 23)

Fig. 23

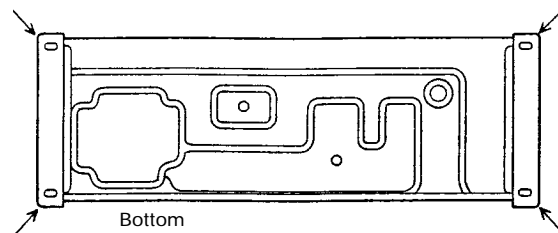

## 4. CONNECTING THE PIPING

### 1. FLARE PROCESSING

- (1) Cut the connection pipe with pipe cutters so that the pipe is not deformed.
- (2) Holding the pipe downward so that cuttings cannot enter the pipe and remove the burrs.
- (3) Remove the flare nut from the indoor unit pipe and outdoor unit and assemble as shown in (Table 3) and insert the flare nut onto the pipe, and flare with a flaring tool.
- (4) Check if the flared part "L" (Fig. 24) is spread uniformly and that there are no cracks.

Table 3

Pipe	Flare nut
Small pipe	Small (width across flats 7/8" (22mm))
Large pipe	Large (width across flats 31/32" (24mm))

Fig. 24

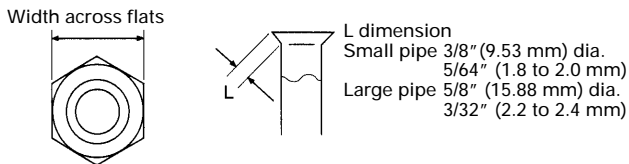

### 2. BENDING PIPES

The pipes are shaped by your hands. Be careful not to collapse them.

Fig. 25

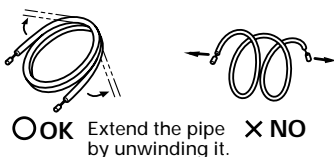

Do not bend the pipes in an angle more than 90°.

When pipes are repeatedly bent or stretched, the material will harden, making it difficult to bend or stretch them any more. Do not bend or stretch the pipes more than three times.

When bending the pipe, do not bend it as is. The pipe will be collapsed. In this case, cut the heat insulating pipe with a sharp cutter as shown in Fig. 26, and bend it after exposing the pipe. After bending the pipe as you want, be sure to put the heat insulating pipe back on the pipe, and secure it with tape.

Fig. 26

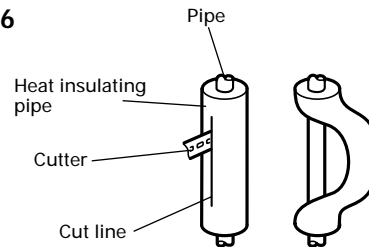

### 3. CONNECTION PIPES

#### (1) Indoor unit side

Centering the pipe against port on the indoor unit, turn the flare nut with your hand. (Fig. 27)

Be sure that the small pipe is completely installed before connecting the large the pipe.

Fig. 27

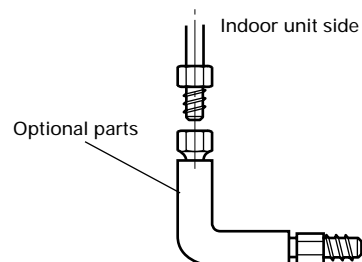

### CAUTION

Be sure to apply the pipe against the port on the indoor unit correctly. If the centering is improper, the flare nut cannot be tightened smoothly. If the flare nut is forced to turn, the threads will be damaged.

When the flare nut is tightened properly by your hand, use a torque wrench to finally tighten it.

Fig. 28

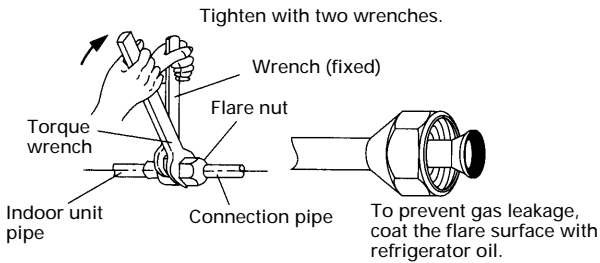

Table 4 Flare nut tightening torque

Pipe	Tightening torque
Small pipe	22.42 to 25.32 ft. lbs (310 to 350 kgf · cm)
Large pipe	54.25 to 57.86 ft. lbs (750 to 800 kgf · cm)

Do not remove the cap from the connection pipe before connecting the pipe.

**CAUTION**

Be sure to connect the large pipe after connecting the small pipe completely.

(2) Outdoor unit side

Tighten the flare nut of the connection pipe at the outdoor unit valve connector. The tightening method is the same as that as at the indoor side.

Fig. 29

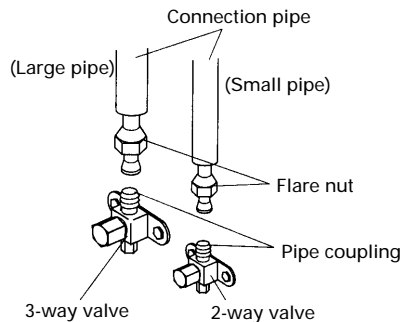

**4. CHECKING THE PIPE CONNECTIONS FOR GAS LEAKING**

For both the indoor and outdoor unit sides, check the joints for gas leaking by the use of a gas leakage detector without fail when the pipes are connected.

**5. HEAT INSULATION ON THE PIPE JOINTS (INDOOR SIDE ONLY)**

Put coupler heat insulator on the joints (indoor side only) (Fig. 30).

Fig. 30

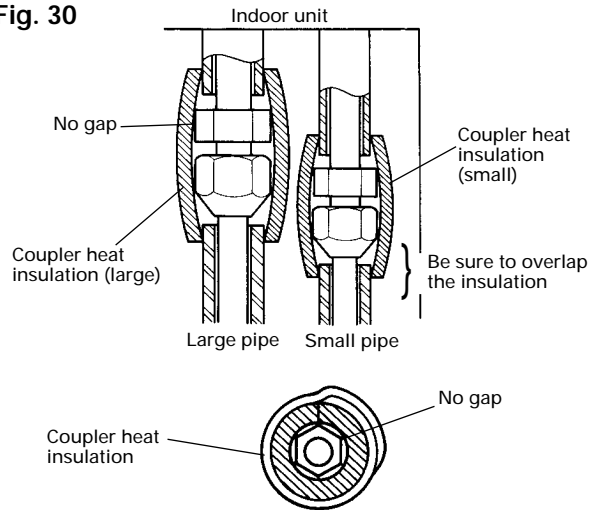

**5. GAS LEAKAGE INSPECTION**

**CAUTION**

After connecting the piping, check the joints for gas leakage with gas leak detector.

## 6. VACUUM PROCESS

### 1. VACUUM

- (1) Remove the cap, and connect the gauge manifold and the vacuum pump to the charging valve by the service hoses.
- (2) Vacuum the indoor unit and the connecting pipes until the pressure in them lowers to below 1.5 mmHg.
- (3) Disconnect the service hoses and fit the cap to the charging valve (Tightening torque : 70 to 90 kgf·cm).
- (4) Remove the blank caps, and fully open the spindles of the 2-way and 3-way valves with a hexagon wrench (Torque : 2-way valve : 70 to 90 kgf · cm, 3-way valve : 100 to 120 kgf · cm).
- (5) Tighten the blank caps of the 2-way valve and 3-way valve to the specified torque (200 to 250 kgf · cm).

Fig. 31

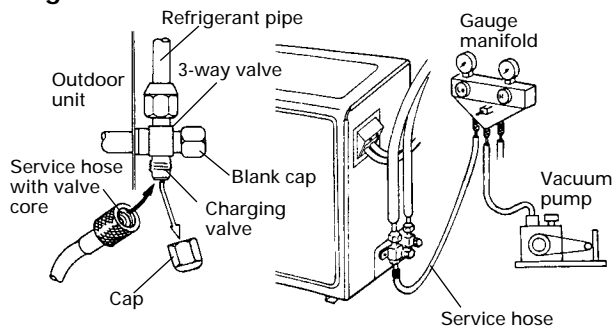

### 2. ADDITIONAL CHARGE

Refrigerant suitable for a piping length of 5 m is charged in the outdoor unit at the factory.

When the piping is longer than 5 m, additional charging is necessary.

For the additional amount, see the table below.

Table 5

Pipe length	25 ft (7.5 m)	33 ft (10 m)	49 ft (15 m)	66 ft (20 m)
Additional refrigerant	None	2.1 oz (60 g)	4.2 oz (120 g)	6.3 oz (180 g)

Between 5 m and 20 m, when using a connection pipe other than that shown in the table, charge additional refrigerant with 0.42 oz (12g) / 3.3 ft (1 m) as the criteria.

### ⚠ CAUTION

- (1) Always pump down the piping before use.
- (2) Add refrigerant from the charging valve after the completion of the work.

## 7. HOW TO CONNECT WIRING TO THE TERMINALS

### A. For solid core wiring (or F-cable)

- (1) Cut the wire end with a wire cutter or wire cutting pliers, then strip the insulation to about 15/16" (25 mm) to expose the solid wire.
- (2) Using a screwdriver, remove the terminal screw (s) on the terminal board.
- (3) Using pliers, bend the solid wire to form a loop suitable for the terminal screw.
- (4) Shape the loop wire properly, place it on the terminal board and tighten securely with the terminal screw using a screwdriver.

### B. For strand wiring

- (1) Cut the wire end with a wire cutter or wire cutting pliers, then strip the insulation to about 3/8" (10 mm) to expose the strand wiring.
- (2) Using a screwdriver, remove the terminal screw (s) on the terminal board.
- (3) Using a round terminal fastener or pliers, securely clamp a round terminal to each stripped wire end.
- (4) Position the round terminal wire, and replace and tighten the terminal screw with a screwdriver.

Fig. 32

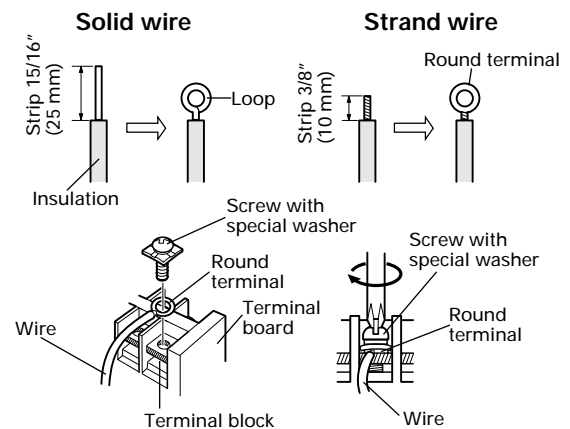

## 8. ELECTRICAL WIRING

### ⚠ CAUTION

- (1) Match the terminal block numbers and connection cord colors with those of the outdoor unit. Erroneous wiring may cause burning of the electric parts.
- (2) Connect the connection cords firmly to the terminal block. Imperfect installation may cause a fire.
- (3) Always fasten the outside covering of the connection cord with the cord clamp. (If the insulator is chafed, electric leakage may occur.)
- (4) Always connect the ground wire.

### 1. INDOOR UNIT SIDE

- (1) Remove the electric component box.

Fig. 33

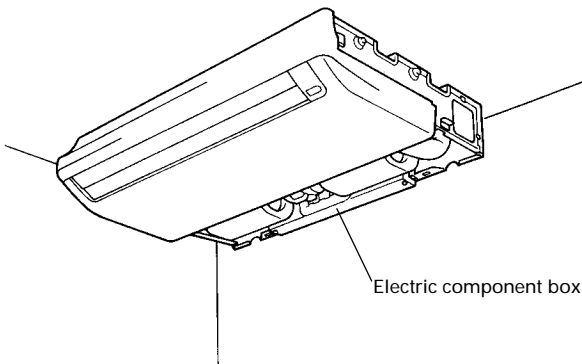
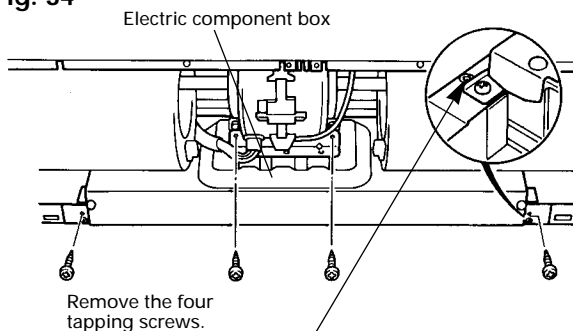

Fig. 34



### ⚠ CAUTION

Do not remove the screws. If the stays are removed, the electric component box will fall.

2. Pull out the electric component box.

Fig. 35

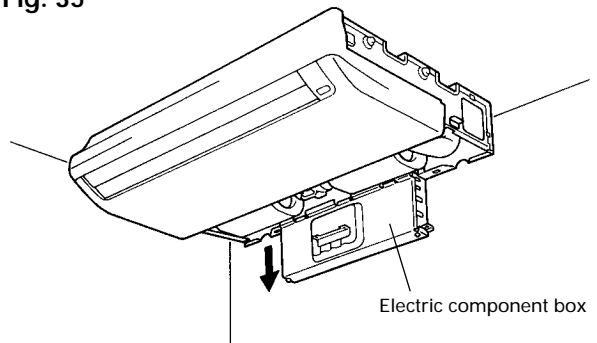

- (3) Remove the electric component box cover.

Fig. 36

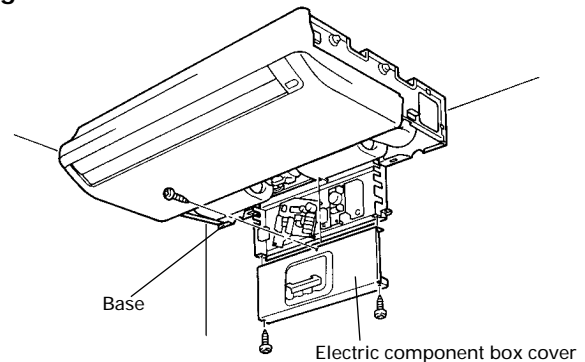

Remove the three tapping screws.

### ⚠ CAUTION

Be careful not to pinch the lead wires between the electric component box and base.

#### (4) Wiring

- ① Process the end of the connection cords to the dimensions shown in Fig. 37.
- ② Connect the end of the connection cord fully into the terminal block.

Fig. 37

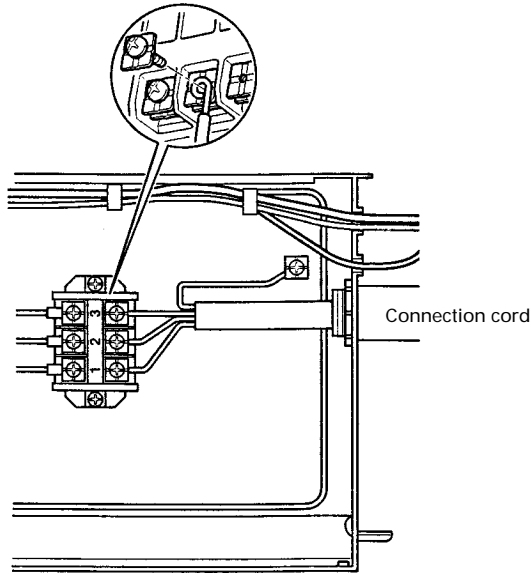

- ③ Fasten the end of the connection cord with the screw.

#### (5) Floor console / Under ceiling select switch

- ① The electrical circuits for this were set for use as a ceiling type at the factory.
- ② The following changes must be made to the settings if the unit is to be used as a floor type.
- ③ Changing the settings for the electrical circuits. Switch 1 (SW1) on the printed circuit board inside the electric component box must be set as follows.

Fig. 38

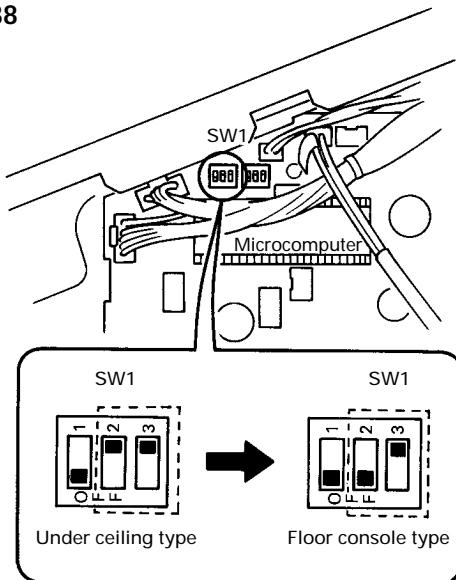

#### 2. OUTDOOR UNIT SIDE

- A. To take off the panel (top), remove the 2 screws.
  - B. Dismount the plugs on the conduit plate.
  - C. Temporarily mount the conduit tubes on the conduit plate.
  - D. Properly connect both the power supply and inter-unit lines to the corresponding terminals on the terminal board.
- Refer to the wiring system diagram in Fig. 41 [Which also appears on the panel (top)].
- E. Ground the unit in accordance with local codes.
  - F. Be sure to size each wire allowing several inches longer than the required length for wiring.
  - G. Use lock nuts to secure the conduit tube.

Fig. 39

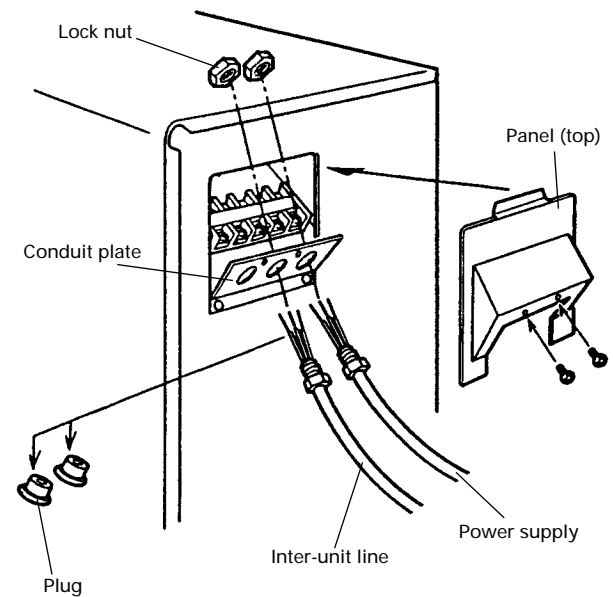

**⚠ CAUTION**

**■ EXAMPLE OF INCORRECT WIRING (Cooling model)**

The following are examples of improper wiring that results in system misoperation. You should confirm that you have wired the units correctly before beginning the test run.

Fig. 40

**Problem 1**

- Short circuit will occur after approx. 3 minutes and the power circuit fuse blows.

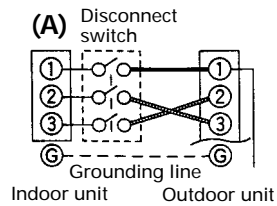

**Problem 2**

- Air conditioner will not operate.

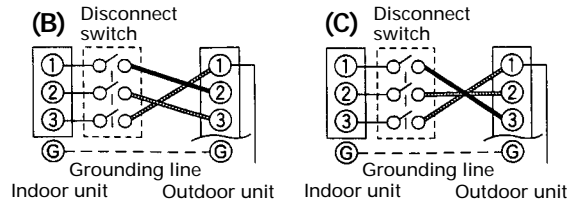

**Problem 3**

- Compressor will not start; only indoor unit will operate.

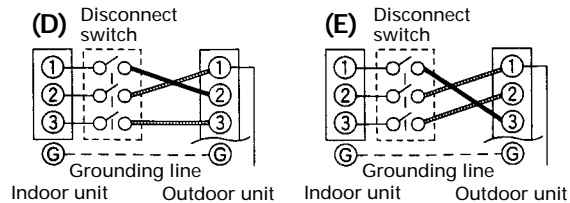

**NOTE**

- Connector trade size for this unit is 1/2". The connector can be bought at a hardware store. Refer to "How to connect wiring to the terminals" for instructions on connecting depending on the wire type you are using.
- The fuse located in the outdoor unit provides power supply protection and may blow when power is applied if the system has been incorrectly wired.

Fig. 41 WIRING SYSTEM DIAGRAM

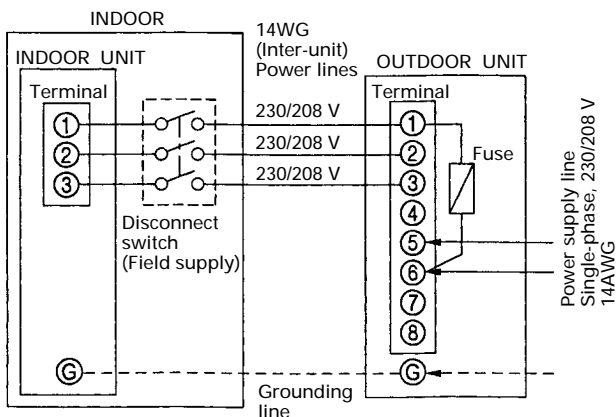

**9. POWER**

**⚠ WARNING**

- (1) The rated voltage of this product is 230/208V A.C. 60Hz.
- (2) Before turning on the verify that the voltage is within the 187V to 253 V range.
- (3) Always use a special branch circuit and install a special receptacle to supply power to the air conditioner.
- (4) Use a circuit breaker and receptacle matched to the capacity of the air conditioner.
- (5) The circuit breaker is installed in the permanent wiring. Always use a circuit that can trip all the poles of the wiring and has an isolation distance of at least 3 mm between the contacts of each pole.
- (6) Perform wiring work in accordance with standards so that the room air conditioner can be operated safely and positively.
- (7) Install a leakage circuit breaker in accordance with the related laws and regulations and electric company standards.

**⚠ CAUTION**

- (1) The power source capacity must be the sum of the room air conditioner current and the current of other electrical appliances. When the current carrying capacity is insufficient, change the circuit capacity.
- (2) When the voltage is low and the air conditioner is difficult to start, contact the power company to have the voltage raised.

## 10. REMOTE CONTROL UNIT INSTALLATION

### CAUTION

- (1) Check that the indoor unit correctly receives the signal from the remote control unit, then install the remote control unit holder.
- (2) Select the remote control unit holder selection site by paying careful attention to the following: Avoid places in direct sunlight. Select a place that will not be affected by the heat from a stove, etc.

### 1. REMOTE CONTROL UNIT HOLDER INSTALLATION

- Install the remote control unit so that the front is facing the photocell. (Fig. 42)

Fig. 42



- Install the remote control unit with a distance of 7m between the remote control unit and the photocell as the criteria. However, when installing the remote control unit, check that it operates positively.
- Install the remote control unit holder to a wall, pillar, etc. with the tapping screw. (Fig. 43)

Fig. 43

#### For use as Handy Type

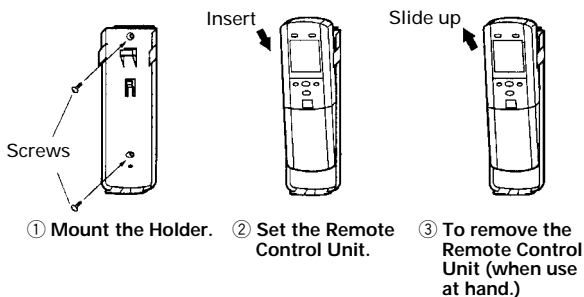

#### For use as Wall Fixing Type

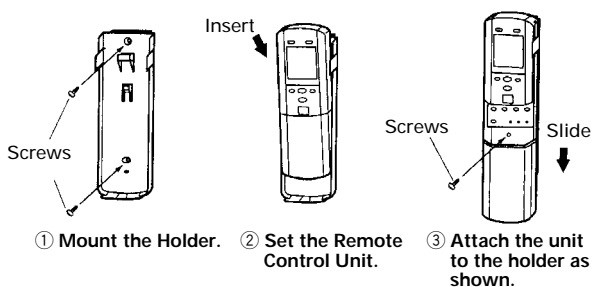

## 2. REMOTE CONTROL UNIT CODE SWITCHING

Fig. 44

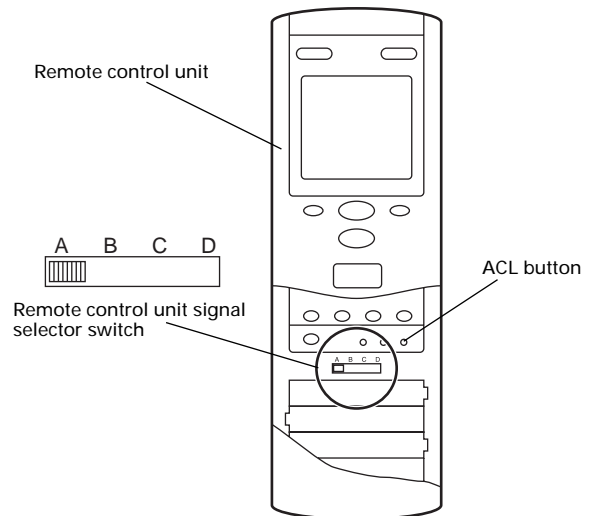
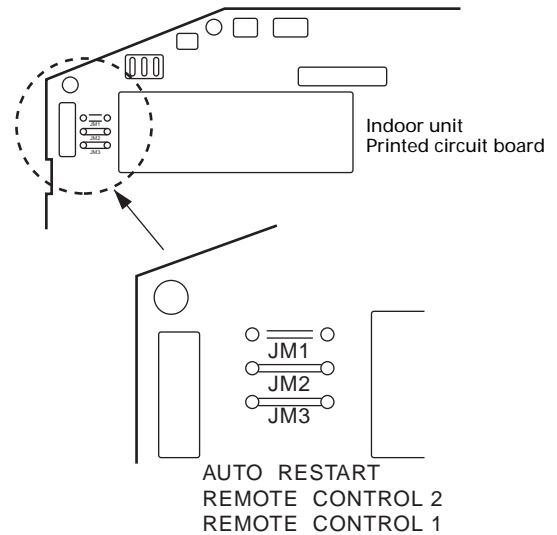

If the jumper wires (JM2 and JM3) are installed onto the control panel, the signal can be adjusted using the remote control unit signal selector switch.

Table 6

Jumper wire		Remote control unit signal selector switch
JM 2	JM 3	
Connect	Connect	A (Primary setting)
Connect	Disconnect	B
Disconnect	Connect	C
Disconnect	Disconnect	D

After setting the remote control unit signal selector switch, press the ACL button.

## 11. TEST RUNNING

### 1. REMOTE CONTROL

- Press the remote control unit test run button while the air conditioner is running.
- At the end of test running, press the remote control unit start/stop button. (Fig. 45)

Fig. 45

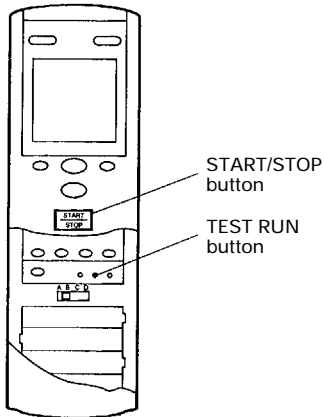

- Run the air conditioner in accordance with the operating manual.

Fig. 46

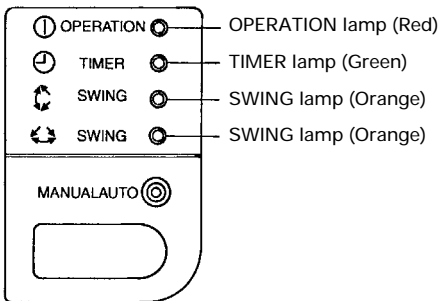

Operation can be checked by lighting and flashing of the display section OPERATION and TIMER lamps. Perform judgement in accordance with the following.

- Test running

When the air conditioner is run by pressing the remote control unit test run button, the OPERATION and TIMER lamps flash slowly at the same time.

- Error

The OPERATION and TIMER lamps operate as follows (Table 7) according to the error contents.

Table 7

Error display		Error contents
<p>OPERATION LAMP</p> <p>ON: 0.5 sec</p> <p>OFF: 5 sec</p> <p>TIMER LAMP</p> <p>ON: 0.1 sec</p> <p>OFF: 0.1 sec</p> <p>Two quick flashes repeated</p>	<p>Room temperature thermistor abnormal temperature detected</p>	
<p>OPERATION LAMP</p> <p>ON: 0.5 sec</p> <p>OFF: 5 sec</p> <p>TIMER LAMP</p> <p>ON: 0.1 sec</p> <p>OFF: 0.1 sec</p> <p>Three quick flashes repeated</p>	<p>Piping thermistor abnormal temperature detected</p>	

### CHECK ITEMS

#### 1. INDOOR UNIT

- (1) Is operation of each button on the remote control unit normal?
- (2) Does each lamp light normally?
- (3) Do not air flow direction louvers operate normally?
- (4) Is the drain normal?
- (5) Is there any abnormal noise and vibration during operation?

#### 2. OUTDOOR UNIT

- (1) Is there any abnormal noise and vibration during operation?
- (2) Will noise, wind, or drain water from the unit disturb the neighbors?
- (3) Is there any gas leakage?
  - Do not operate the air conditioner in the test running state for a long time.
  - For the operation method, refer to the operating manual and perform operation check.

## 12. FRESH AIR INTAKE

- Open the hole and connect the duct. (Fig. 47)

Fig. 47

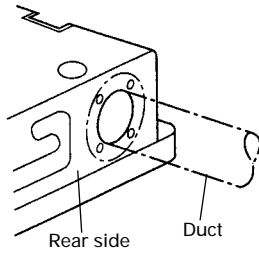

## 13. MOUNT THE COVER PLATE AND THE INTAKE GRILLE

### 1. MOUNT THE COVER PLATE (RIGHT)

- (1) Cut a pipe exit hole in the right plate. This is only when the pipe exits from the right side. (This operation is not required when the protrusion is on the top or rear.)

Fig. 48

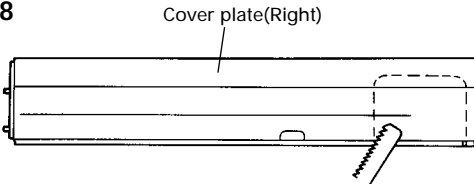

- (2) Join the cover plates (right) and mount with screws. (Fig. 49)

Fig. 49

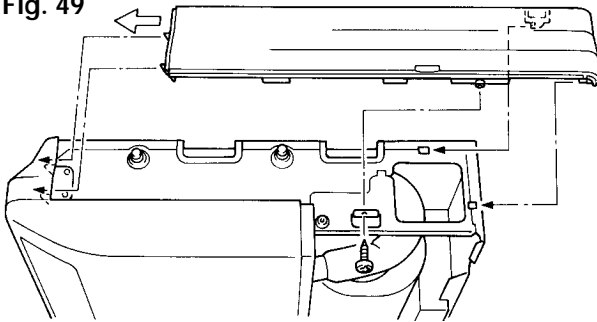

### 2. MOUNT THE COVER PLATE (LEFT)

- (1) Join the cover plates (left) and mount with screws.

Fig. 50

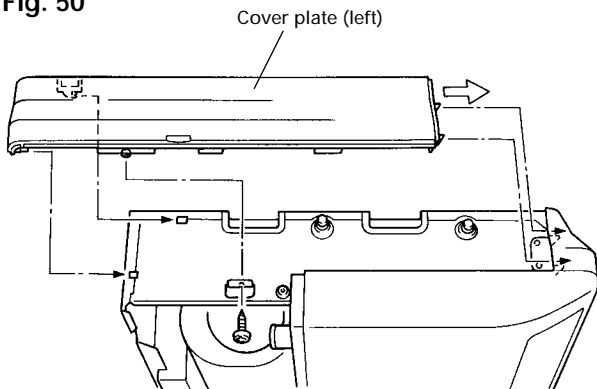

### 3. MOUNT THE INTAKE GRILLE

- (1) Cut the right side of the intake grille. This is only when the pipe exits from the right side. (Fig. 51)

Fig. 51

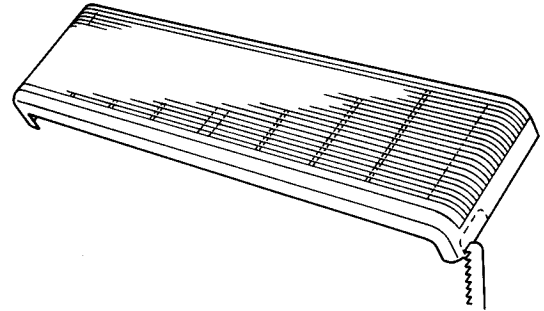

- (2) Insert the hinges on the bottom of the intake grille into the holes in the base assembly. Then mount the arms to the three areas on the top of the intake grille. (Fig. 52)

Fig. 52

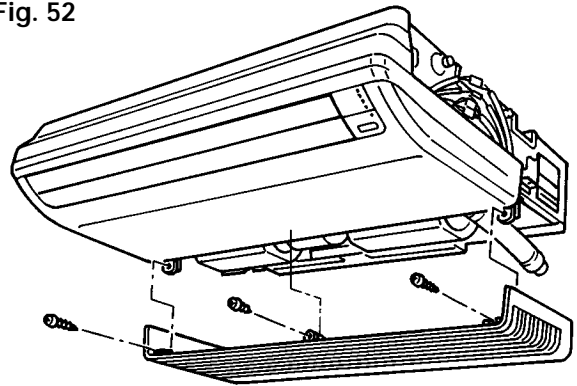



FUJITSU GENERAL AMERICA, INC.

353 Rt. 46 W.  
Fairfield, NJ 07004  
888-888-FGAI  
[www.fujitsugeneral.com](http://www.fujitsugeneral.com)