

INSTALLATION MANUAL

CEILING SUSPENDED TYPE

SPLIT TYPE AIR CONDITIONER

IMPORTANT!

Please Read Before Starting

This air conditioning system meets strict safety and operating standards. As the installer or service person, it is an important part of your job to install or service the system so it operates safely and efficiently.

For safe installation and trouble-free operation, you must:

- Carefully read this instruction booklet before beginning.
- Follow each installation or repair step exactly as shown.
- Observe all local, state, and national electrical codes.
- Pay close attention to all danger, warning, and caution notices given in this manual.



WARNING

This symbol refers to a hazard or unsafe practice which can result in severe personal injury or death.



CAUTION

This symbol refers to a hazard or unsafe practice which can result in personal injury and the potential for product or property damage.

- Hazard alerting symbols



Electrical



Safety/alert

If Necessary, Get Help

These instructions are all you need for most installation sites and maintenance conditions. If you require help for a special problem, contact our sales/service outlet or your certified dealer for additional instructions.

In Case of Improper Installation

The manufacturer shall in no way be responsible for improper installation or maintenance service, including failure to follow the instructions in this document.

SPECIAL PRECAUTIONS

When Wiring

ELECTRICAL SHOCK CAN CAUSE SEVERE PERSONAL INJURY OR DEATH. ONLY A QUALIFIED, EXPERIENCED ELECTRICIAN SHOULD ATTEMPT TO WIRE THIS SYSTEM.

- Do not supply power to the unit until all wiring and tubing are completed or reconnected and checked.
- Highly dangerous electrical voltages are used in this system. Carefully refer to the wiring diagram and these instructions when wiring. Improper connections and inadequate grounding can cause **accidental injury or death**.

- **Ground the unit** following local electrical codes.
- Connect all wiring tightly. Loose wiring may cause overheating at connection points and a possible fire hazard.

When Transporting

Be careful when picking up and moving the indoor and outdoor units. Get a partner to help, and bend your knees when lifting to reduce strain on your back. Sharp edges or thin aluminum fins on the air conditioner can cut your fingers.

When Installing...

...In a Ceiling or Wall

Make sure the ceiling/wall is strong enough to hold the unit's weight. It may be necessary to construct a strong wood or metal frame to provide added support.

...In a Room

Properly insulate any tubing run inside a room to prevent "sweating" that can cause dripping and water damage to walls and floors.

...In Moist or Uneven Locations

Use a raised concrete pad or concrete blocks to provide a solid, level foundation for the outdoor unit. This prevents water damage and abnormal vibration.

...In an Area with High Winds

Securely anchor the outdoor unit down with bolts and a metal frame. Provide a suitable air baffle.

...In a Snowy Area (for Heat Pump-type Systems)

Install the outdoor unit on a raised platform that is higher than drifting snow. Provide snow vents.

When Connecting Refrigerant Tubing

- Keep all tubing runs as short as possible.
- Use the flare method for connecting tubing.
- Apply refrigerant lubricant to the matching surfaces of the flare and union tubes before connecting them, then tighten the nut with a torque wrench for a leak-free connection.
- Check carefully for leaks before starting the test run.

NOTE:

Depending on the system type, liquid and gas lines may be either narrow or wide. Therefore, to avoid confusion the refrigerant tubing for your particular model is specified as either "small" or "large" rather than as "liquid" or "gas".

When Servicing

- Turn the power OFF at the main circuit breaker panel before opening the unit to check or repair electrical parts and wiring.
- Keep your fingers and clothing away from any moving parts.
- Clean up the site after you finish, remembering to check that no metal scraps or bits of wiring have been left inside the unit being serviced.
- After installation, explain correct operation to the customer, using the operating manual.

Fig. 1 INDOOR UNIT

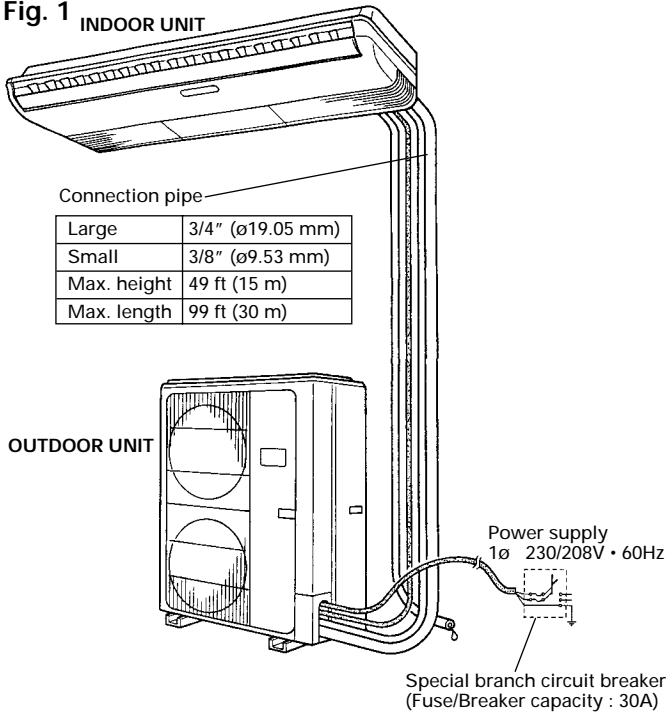

GENERAL

This INSTALLATION MANUAL briefly outlines where and how to install the air conditioning system. Please read over the entire set of instructions for the indoor and outdoor units and make sure all accessory parts listed are with the system before beginning.

1. TYPE OF COPPER PIPE AND INSULATION MATERIAL

Copper tubing for connecting the outdoor unit to the indoor unit and insulation material is available for purchase locally. When you purchase them, please specify the following.

- (1) Deoxidized annealed copper pipe for refrigerant piping as:

Table 1

	Outer diameter	Thickness
Small pipe	3/8" (9.53 mm)	1/32" (0.8 mm)
Large pipe	3/4" (19.05 mm)	3/64" (1.0 mm)

Cut each pipe to the appropriate length +12" (30 cm) to 16" (40 cm) to dampen vibration between units.

— 30,000 BTU/h Type only —

⚠ CAUTION

- (1) Limit the height difference between the indoor and outdoor units to within 49 ft. (15 m).
- (2) The maximum length of the piping is 99 ft. (30 m). If the units are further apart than this, correct operation can not be guaranteed.

— 36,000 BTU/h Type only —

⚠ CAUTION

- (1) Limit the height difference between the indoor and outdoor units to within 99 ft. (30 m).
- (2) The maximum length of the piping is 164 ft. (50 m). If the units are further apart than this, correct operation can not be guaranteed.

- (2) Foamed polyethylene insulation for copper pipes as required to precise length of piping. Wall thickness of the insulation should not be less than 5/16" (8 mm).
- (3) Use insulated copper wire for field wiring.

⚠ CAUTION

Check local electrical codes and regulations before obtaining wire. Also, check any specified instructions or limitations.

2. ADDITIONAL MATERIALS REQUIRED FOR INSTALLATION

- (1) Refrigeration (armored) tape
- (2) Insulated staples or clamps for connecting wire (See your local electrical codes.)
- (3) Putty
- (4) Refrigeration lubricant
- (5) Clamps or saddles to secure refrigerant piping

3. OPERATING RANGE

— 30,000 BTU/h Type only —

	Temperature	Indoor air intake	Outdoor air intake
Cooling	Maximum	90°F DB, 73°F WB	115°F DB
	Minimum	65°F DB, 57°F WB	70° F DB

— 36,000 BTU/h Type only —

	Temperature	Indoor air intake	Outdoor air intake
Cooling	Maximum	90°F DB, 73°F WB	115°F DB
	Minimum	65°F DB, 57°F WB	32° F DB

ELECTRICAL REQUIREMENT

Always make the air conditioner power supply a special branch circuit and provide a special switch and receptacle. Do not extend the power cord.









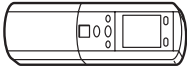
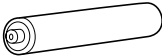
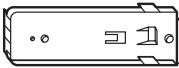

⚠ CAUTION

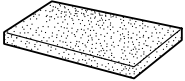
MINIMUM CIRCUIT AMPACITY 20A
 MAXIMUM OVERCURRENT PROTECTION 30A
 (TIME DELAY FUSE OR HACR TYPE CIRCUIT BREAKER)

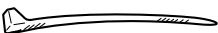

STANDARD PARTS

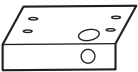
The following installation parts are furnished.
Use them as required.

INDOOR UNIT ACCESSORIES

Name and Shape	Q'ty	Application
Remote control unit 	1	Use for air conditioner operation
Battery (penlight) 	4	For remote control unit
Remote control unit holder 	1	For mounting the remote control unit
Tapping screw (ø3 x 12) 	3	For remote control unit holder installation
Drain hose insulation 	1	Adhesive type 70 x 230
VT wire 	1	For fixing the drain hose L 280 mm
Coupler heat insulator (Large) 	2	For indoor side pipe joint (large pipe)
Coupler heat insulator (small) 	1	For indoor side pipe joint (small pipe)
Nylon fastener 	Large 4 Small 4	For fixing the coupler heat insulator
Special nut A (large flange) 	4	For installing indoor unit
Special nut B (small flange) 	4	For installing indoor unit
Installation template 	1	For positioning the indoor unit
Auxiliary pipe assembly 	1	For connecting the piping

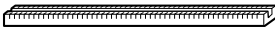
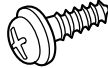
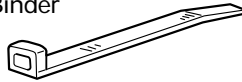
OUTDOOR UNIT ACCESSORIES

Name and Shape	Q'ty	Application
Auxiliary pipe assembly 	1	For wiring conduit (gas side) connection (May not be supplied, depending on the model)
Edge cover 	1	For wiring conduit installation hole edge protection
Tapping screw 	2	• For cabinet A and cabinet D mounting (1) • Spare (1)
Binder 	1	For power cord binding
Putty 	1	For sealing
Coupler heat insulation 	1	For outdoor side pipe joint

SELECTING THE MOUNTING POSITION

⚠ WARNING

Install at a place that can withstand the weight of the indoor and outdoor units and install positively so that the units will not topple or fall.

⚠ CAUTION

- (1) Do not install where there is the danger of combustible gas leakage.
- (2) Do not install the unit near a source of heat, steam, or flammable gas..
- (3) If children under 10 years old may approach the unit, take preventive measures so that they cannot reach the unit.

Decide the installing position with the customer as follows:

1. INDOOR UNIT

- (1) Install the indoor unit level on a strong wall which is not subject to vibration.
- (2) The inlet and outlet ports should not be obstructed : the air should be able to blow all over the room.
- (3) Do not install the unit where it will be exposed to direct sunlight.
- (4) Install the unit where connection to the outdoor unit is easy.
- (5) Install the unit where the drain pipe can be easily installed.
- (6) Take servicing, etc. into consideration and leave the spaces shown in (Fig. 2 or 3). Also install the unit where the filter can be removed.

Fig. 2

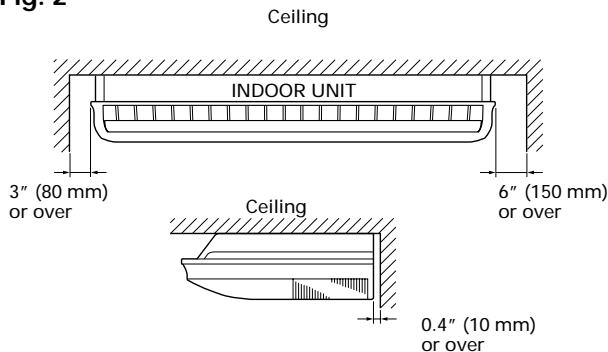

[FOR HALF CONCEALED INSTALLATION]

Fig. 3

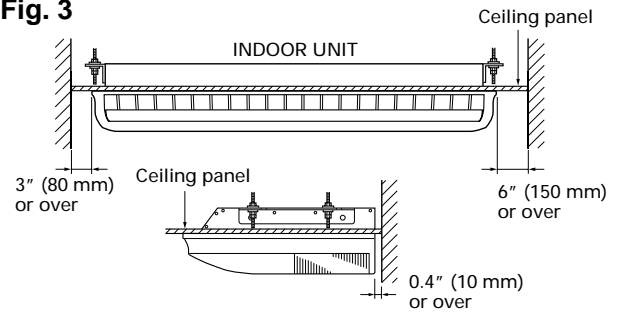

2. OUTDOOR UNIT

⚠ WARNING

- (1) Install the unit where it will not be tilted by more than 5°.
- (2) When installing the outdoor unit where it may be exposed to strong wind, fasten it securely.

(1) Leave the space indicated for good air flow (Fig. 4).

Fig. 4

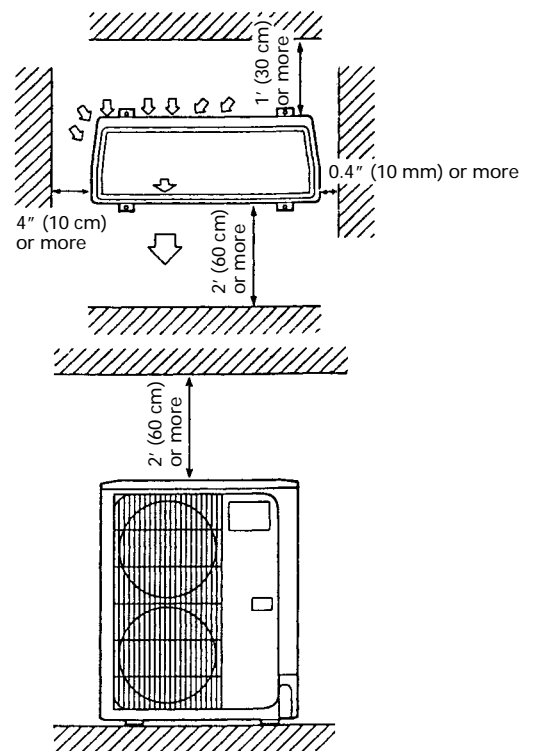

- (2) If possible, do not install the unit where it will be exposed to direct sunlight (If necessary, install a blind that does not interfere with the air flow.)
- (3) Install the outdoor unit where it will not get dirty or get wet by rain as much as possible.
- (4) Install the unit where connection to the indoor unit is easy, and nearby.

INSTALLATION PROCEDURE

Install the room air conditioner as follows:

1. PREPARING INDOOR UNIT INSTALLATION

1. REMOVE THE INTAKE GRILLE AND SIDE COVER.

- (1) Remove the two Air filters. (Fig.5)
- (2) Remove the two Intake grilles. (Fig.5)
 - For ④ Left rear drain and ⑤ Left drain: Remove air filters and intake grilles at three places. (Refer to "2. INDOOR UNIT INSTALLATION".)
- (3) Remove the Side cover A (Right side) and Side cover B (Right and Left side).
 - For ⑤ Left drain : Remove both the Side cover A (Right and Left side). (Refer to "2. INDOOR UNIT INSTALLATION".)
- (4) This air conditioner can be set up to intake fresh air. For information about how to install for fresh-air intake, refer to "15. FRESH-AIR INTAKE".

Fig. 5

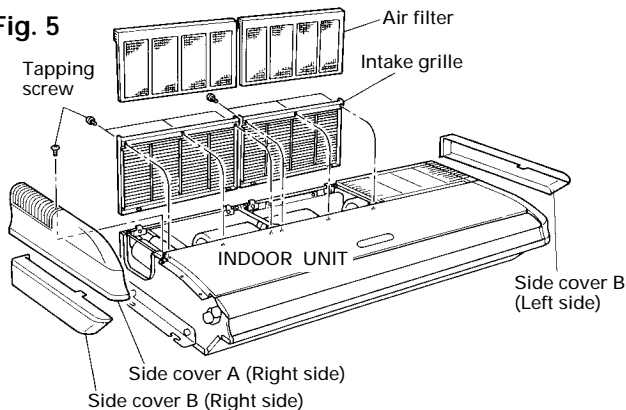

2. INDOOR UNIT INSTALLATION

You can use the accessory template to help you install the indoor unit. The template helps you determine the appropriate locations for suspension bolts and pipe openings (drain pipe and connection cord).

Fig. 6

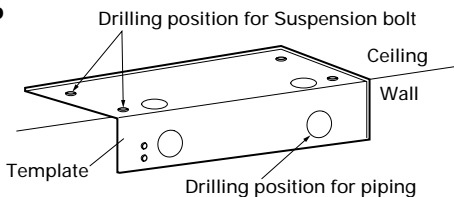

1. LOCATION OF CEILING SUSPENSION BOLTS

Fig. 7

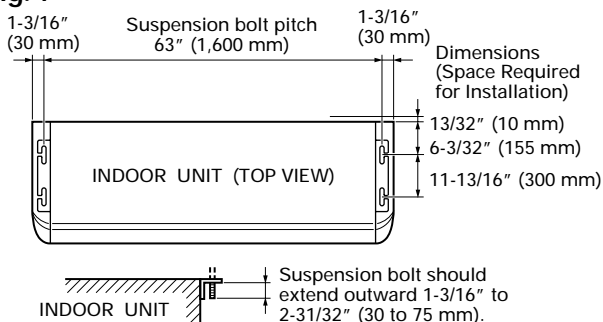

[For Half-Concealed Installation]

- Suspension-bolt pitch should be as shown in Fig. 7.

Fig. 8

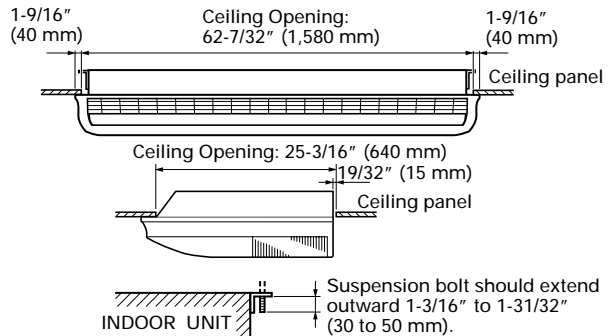

2. SELECT PIPING DIRECTION

Select connection piping and drain piping directions. (Fig.9)

Fig. 9

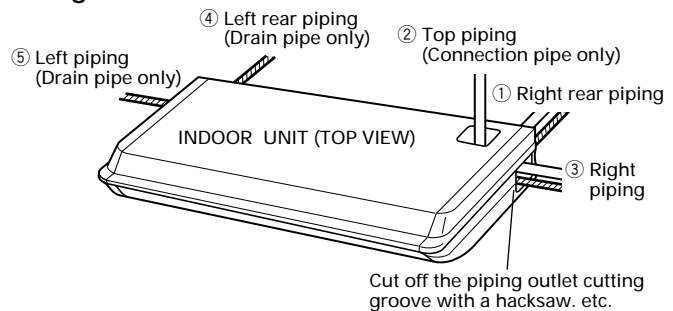

[For ④ Left rear piping, ⑤ Left piping]

- Transfer the Drain cap and Drain cap seal.

Fig. 10

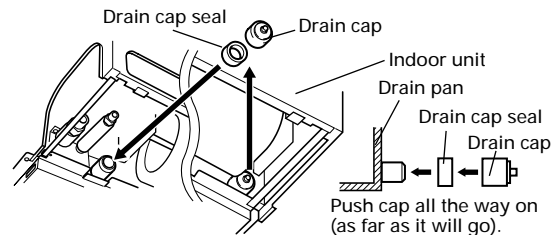

3. DRILLING THE HOLES AND ATTACHING THE SUSPENSION BOLTS

- (1) Drill $\phi 1$ ($\phi 25\text{mm}$) holes at the suspension-bolt locations.
- (2) Install the bolts, then temporarily attach Special nuts A and B and a normal M10 nut to each bolt. (The two special nuts are provided with the unit. The M10 nut must be obtained locally.) Refer to Fig. 11.

Bolt Strength	7.23 to 10.85 ft. lbs (100 to 150 kgf)
----------------------	--

Fig. 11

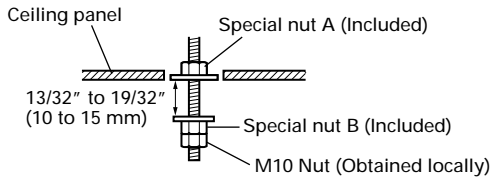

[If using anchor bolts]

- (1) Drill holes for anchor bolts at the locations at which you will set the suspension bolts. Note that anchor bolts are M10 bolts (to be obtained locally).
- (2) Install the anchor bolts, then temporarily attach special nut "B" (included) and a locally-procured M10 nut to each of the bolts. (See Fig. 12.)

Anchor-Bolt Strength	7.23 to 10.85 ft. lbs (100 to 150 kgf)
-----------------------------	--

Fig. 12

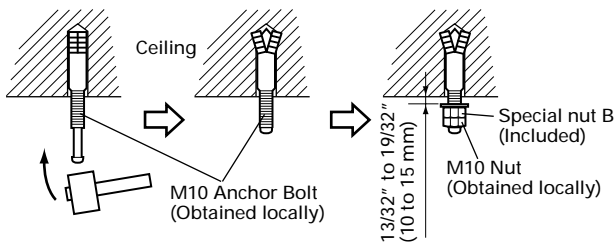

4. INSTALLING THE INDOOR UNIT

- (1) Lift unit so that suspension bolts pass through the suspension fittings at the sides (four places), and slide the unit back. (See Figs. 13 and 14.)

Fig. 13

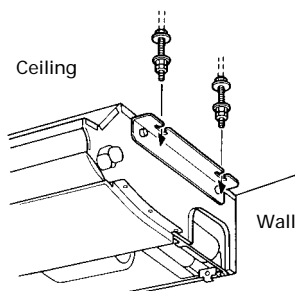
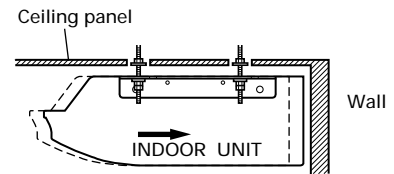

Fig. 14



- (2) Fasten the indoor unit into place by tightening-up the special "B" bolts and the M10 nuts. Make sure that unit is secure and will not shift back and forth.

[For Half-Concealed Installation]

When installing the indoor unit in a semi-concealed orientation, make sure to reinforce the insulation of the unit on all sides. Drops of water may fall from the unit if it is not thoroughly insulated.

Fig. 15

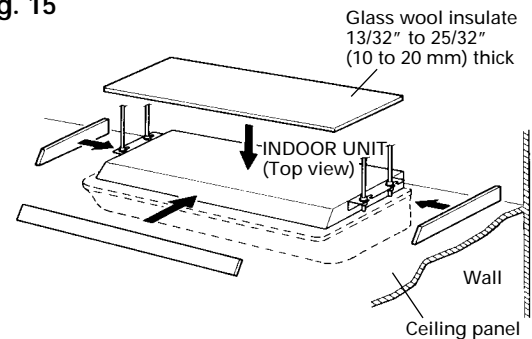

⚠ CAUTION
In order to check the drainage, be sure to use a level during installation of the indoor unit. If the installation site of the indoor unit is not level, water leakage may occur.

3. OUTDOOR UNIT INSTALLATION

1. OUTDOOR UNIT PROCESSING

When the outdoor unit will be exposed to strong wind, fasten it with bolts at the four places indicated by the arrows. (Fig. 16)

Fig. 16

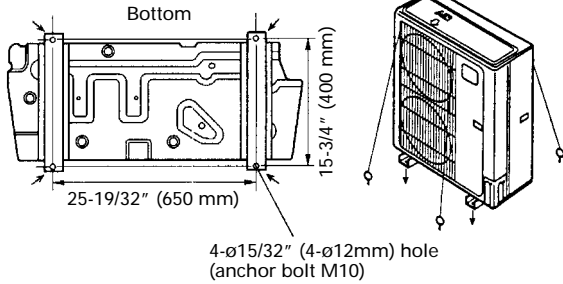

2. OUTDOOR UNIT CONNECTION CORD AND PIPE CONNECTION PREPARATIONS

(1) Piping and connection cord mounting direction (4-way mounting possible).

Fig. 17

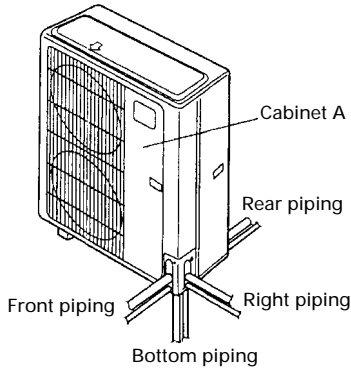

(2) Remove outdoor unit cabinet A and cabinet D.

Fig. 18

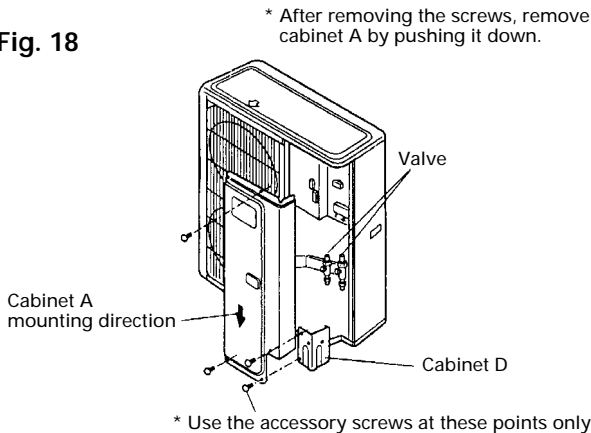

(3) Open the piping knockout holes of the desired direction with nippers, etc. After opening the knockout holes, install the accessory edge cover to protect the opened places.

Fig. 19

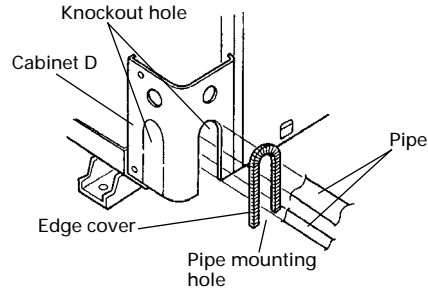

(4) Always use a drain pipe at two places.

Fig. 20

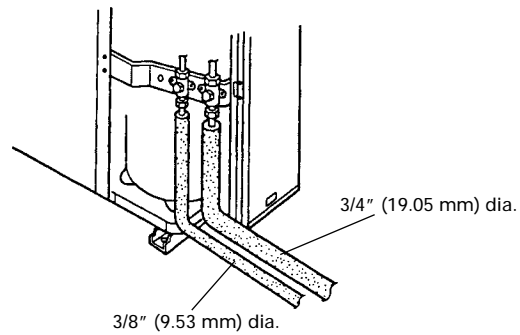

4. CONNECTING THE PIPING

1. FLARE PROCESSING

- (1) Cut the connection pipe with pipe cutters so that the pipe is not deformed.
- (2) Holding the pipe downward so that cuttings cannot enter the pipe, remove the burrs.
- (3) Remove the flare nut from the indoor unit pipe and outdoor unit and assemble as shown in (Table 3). Insert the flare nut onto the pipe, and flare with a flaring tool.
- (4) Check if the flared part "L" (Fig. 21) is spread uniformly and that there are no cracks.

Table 3

Pipe	Flare nut
Small pipe	Small (width across flats 7/8" (22 mm))
Large pipe	Large (width across flats 1-13/32" (36 mm))

Fig. 21

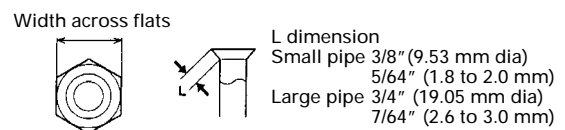

2. BENDING PIPES

The pipes are shaped by your hands. Be careful not to collapse them.

Fig. 22

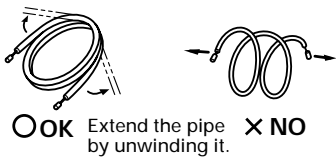

Do not bend the pipes in an angle less than 90°.

When the pipes are bent and stretched repeatedly, the material will be hardened, causing the pipes no longer be bent or stretched. Be sure to limit number of bending and stretchings to three times.

When bending the pipe, do not bend it as is. The pipe will be collapsed. In this case, cut the heat insulating pipe with a sharp cutter as shown in Fig. 23, and bend it after exposing the pipe. After bending the pipe as you want, be sure to put the heat insulating pipe back on the pipe, and secure it with tape.

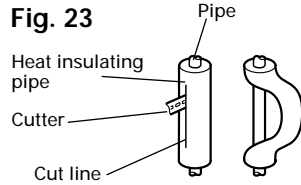

3. CONNECTION PIPES

[Indoor unit side]

(1) Remove the filter guide. (Fig. 24)

Fig. 24

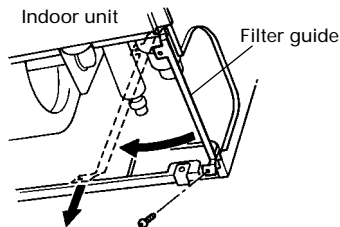

(2) Attach the connection pipe. (Fig. 25)

Fig. 25

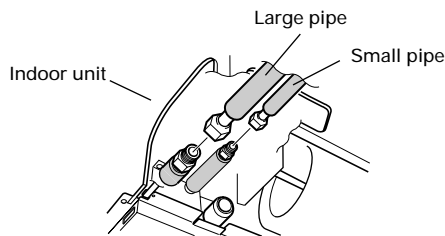

- For ② Top piping and ③ Right piping connections, use the Auxiliary pipe (large pipe) provided. (See Fig. 26)

Fig. 26

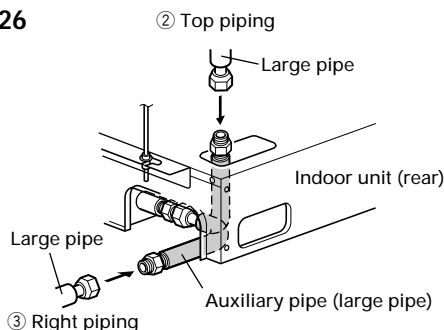

CAUTION

Be sure to apply the pipe against the port on the indoor unit correctly. If the centering is improper, the flare nut cannot be tightened smoothly. If the flare nut is forced to turn, the threads will be damaged.

When the flare nut is tightened properly by your hand, hold the body side coupling with a separate spanner, then tighten with a torque wrench. (Fig. 27)

Fig. 27

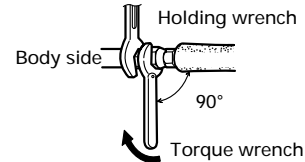

CAUTION

Hold the torque wrench at its grip, keeping it in the right angle with the pipe as shown in Fig. 27, in order to tighten the flare nut correctly.

Table 4 : Flare nut tightening torque

Pipe	Tightening torque
Small pipe	22.42 to 25.32 ft. lbs (310 to 350 kgf · cm)
Large pipe	57.86 to 72.37 ft. lbs (800 to 1,000 kgf · cm)

[Outdoor unit side]

(1) Tighten the flare nut of the connection pipe at the outdoor unit valve connector. The tightening method is the same as that as at the indoor side.

(2) Seal with the accessory putty so that water does not enter at the top of the pipe insulation installed to the connection pipe (large pipe and small pipe).

Fig. 28

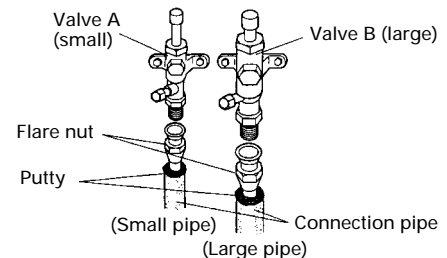

5. VACUUMING AND ADDITIONAL CHARGE

1. VACUUMING

- (1) Vacuuming inside the indoor unit and the piping to a pressure of 1.5 mmHg abs or less from the charging valve with a vacuum pump.
- (2) After vacuuming inside the indoor unit and the piping, remove the cap of the two valves.
- (3) Open the handle of the two valves from the closed state (Table 5).
- (4) Tighten the cap and charging valve of the two valves to the specified torque (Table 6).

Table 5

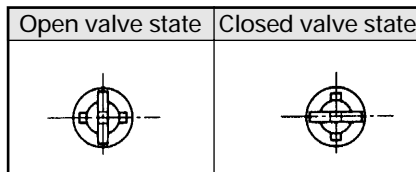
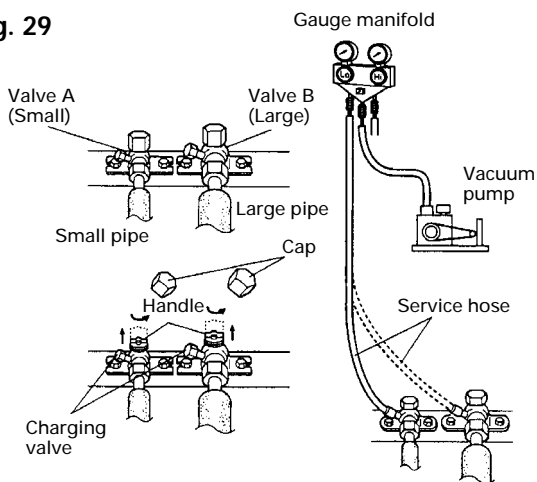

Table 6

	Tightening torque	
	Large valve	Small valve
Cap	10.85 to 14.47 ft. lbs (150 to 200 kgf-cm)	
Charging valve	5.07 to 6.51 ft. lbs (70 to 90 kgf-cm)	

* If the handle is not fully open, performance will drop and an abnormal sound will be generated.

Fig. 29



2. ADDITIONAL CHARGE

30,000 BTU/h Type only

Refrigerant suitable for a piping length of 25ft. (7.5 m) is charged in the outdoor unit at the factory. When the piping is longer than 25ft. (7.5 m), additional charging is necessary. For the additional amount, see the table below.

Table 7-1

Pipe length	25 ft (7.5 m)	33 ft (10 m)	49 ft (20 m)	99 ft (30 m)
Additional refrigerant	None	1.5 oz (43 g)	7.5 oz (213 g)	13.5 oz (383g)

Between 25 ft (7.5 m) and 99 ft (30 m), when using a connection pipe other than that in the table, charge additional refrigerant with 0.6 oz (17 g)/3.3 ft (1 m) as the criteria.

36,000 BTU/h Type only

Refrigerant suitable for a piping length of 66ft. (20 mm) is charged in the outdoor unit at the factory.

When the piping is longer than 66ft. (20 mm), additional charging is necessary.

For the additional amount, see the table below.

Table 7-2

Pipe length	66 ft (20 m)	99 ft (30 m)	132 ft (40 m)	164 ft (50 m)
Additional refrigerant	None	14.1 oz (400 g)	28.2 oz (800 g)	42.3 oz (1,200g)

Between 66 ft (20 m) and 164 ft (50 m), when using a connection pipe other than that in the table, charge additional refrigerant with 1.41 oz (40 g)/3.3 ft (1 m) as the criteria.

CAUTION

- (1) When charging the refrigerant, always use a measuring cylinder.
- (2) Add refrigerant from the charging valve after the completion of the work.

6. GAS LEAKAGE INSPECTION

CAUTION

After connecting the piping, check the joints for gas leakage with gas leak detector.

7. INSTALLING THE COUPLER HEAT INSULATION

After checking for gas leaks, insulate by wrapping insulation around the two parts (large and small) of the indoor unit coupling, using the coupler heat insulation.

After installing the coupler heat insulation, wrap both ends with vinyl tape so that there is no gap.

Secure both ends of the heat insulation material using nylon fasteners.

Fig. 30

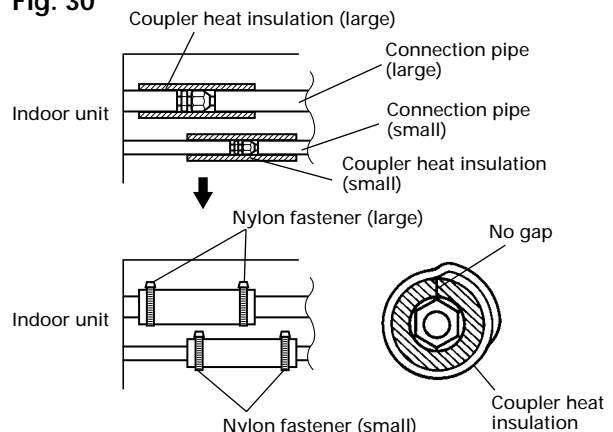

- When using an auxiliary pipe, make sure that the fastener used is insulated in the same way.

8. DRAIN PIPING

- Install the drain pipe with downward gradient (1/50 to 1/100) and so there are no rises or traps in the pipe.
- Use general hard polyvinyl chloride pipe (VP25) [outside diameter 1-1/2" (38 mm)].
- During installation of the drain pipe, be careful to avoid applying pressure to the drain port of the indoor unit.
- When the pipe is long, install supporters. (Fig. 31)
- Do not perform air bleeding.
- Always heat insulate (11/32" (8 mm) or over thick) the indoor side of the drain pipe.

Fig. 31

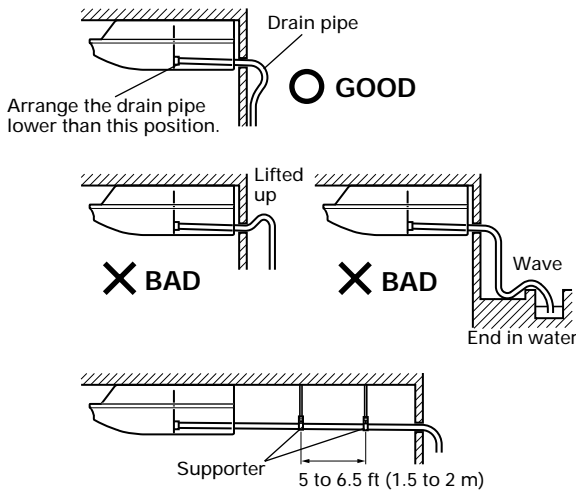

- (1) Install insulation for the drain pipe. (See Figs. 32 and 33.)
Cut the included insulation material to an appropriate size and adhere it to the pipe.

Fig. 32

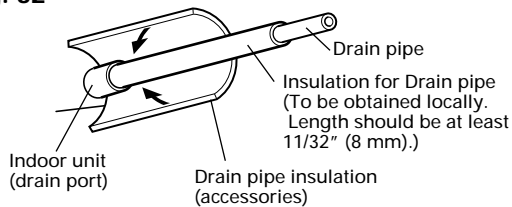
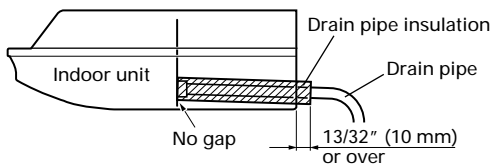
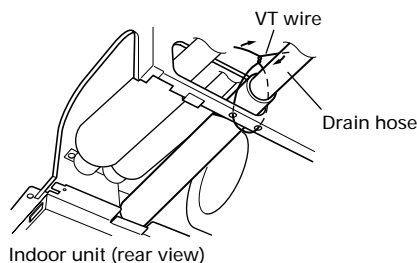

Fig. 33



- (2) If " ① Right rear piping ": fasten the drain pipe with VT wire so that the pipe slopes correctly within the indoor unit. (Fig. 34)

Fig. 34



9. ELECTRICAL WIRING

HOW TO CONNECT WIRING TO THE TERMINALS

A. For solid core wiring (or F-cable)

- (1) Cut the wire end with a wire cutter or wire cutting pliers, then strip the insulation to about 15/16" (25 mm) to expose the solid wire.
- (2) Using a screwdriver, remove the terminal screw (s) on the terminal board.
- (3) Using pliers, bend the solid wire to form a loop suitable for the terminal screw.
- (4) Shape the loop wire properly, place it on the terminal board and tighten securely with the terminal screw using a screwdriver.

B. For strand wiring

- (1) Cut the wire end with a wire cutter or wire cutting pliers, then strip the insulation to about 3/8" (10 mm) to expose the strand wiring.
- (2) Using a screwdriver, remove the terminal screw (s) on the terminal board.
- (3) Using a round terminal fastener or pliers, securely clamp a round terminal to each stripped wire end.
- (4) Position the round terminal wire, and replace and tighten the terminal screw with a screwdriver.

Fig. 35

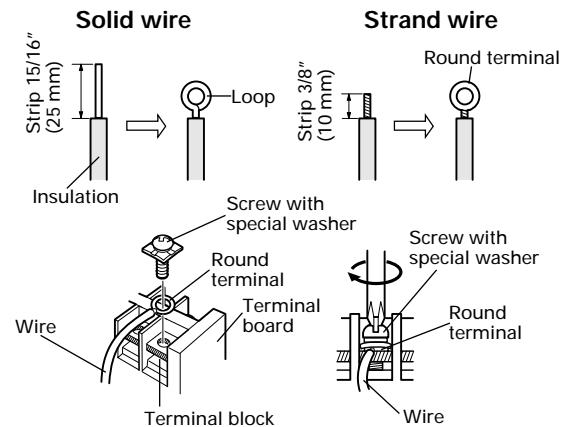

1. INDOOR UNIT SIDE

- (1) Remove the two tapping screws and pull the control box downward. (Fig. 36)

Fig. 36

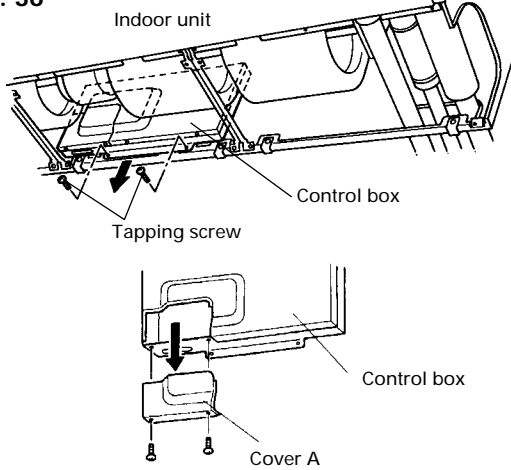

- (2) Remove the Cover A and install the Connection cord. (Figs. 36 and 37)
- (3) Reattach Cover A. Then fasten the control box back into its original position with the two tapping screws.
- (4) Attach the connection cord and cable clips. Make sure that they are positioned so that they will not interfere with opening and closing of the intake grille or with removal and installation of the air filters. (Fig. 38)

Fig. 37

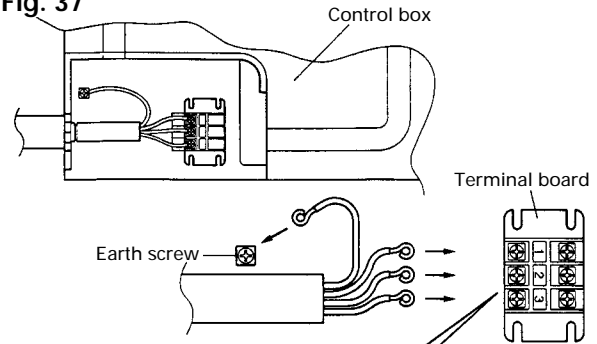

Fig. 38

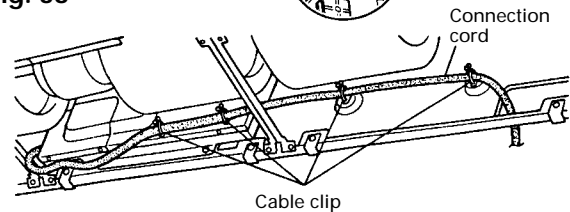
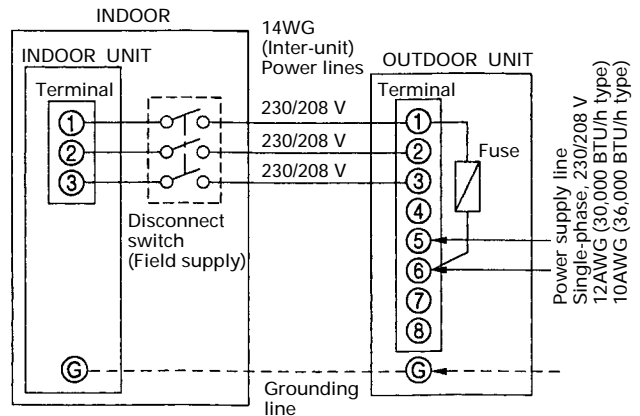

Fig. 39



⚠ WARNING

- (1) Before starting work, check that power is not being supplied to the outdoor unit.
- (2) Match the terminal board numbers and connection cord colors with those of the outdoor unit.
Erroneous wiring may cause burning of the electric parts.
- (3) Connect the connection cord firmly to the terminal board. Imperfect installation may cause a fire.
- (4) Always fasten the outside covering of the connection cord with the cord clamp. (If the insulator is chafed, electric leakage may occur.)
- (5) Always connect the ground wire.

2. OUTDOOR UNIT SIDE

- (1) Dismount the plugs on the Cabinet D.
- (2) Temporarily mount the conduit tubes on the Cabinet D.
- (3) Properly connect both the power supply and inter-unit lines to the corresponding terminals on the terminal board.
Refer to the wiring system diagram in Fig. 39.
- (4) Ground the unit in accordance with local codes.
- (5) Be sure to size each wire allowing several inches longer than the required length for wiring.
- (6) Use lock nuts to secure the conduit tube.

Fig. 40

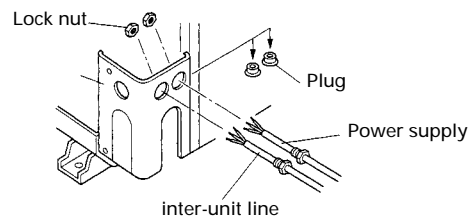

After connecting the connection cord, install cabinet A.

Fig. 41

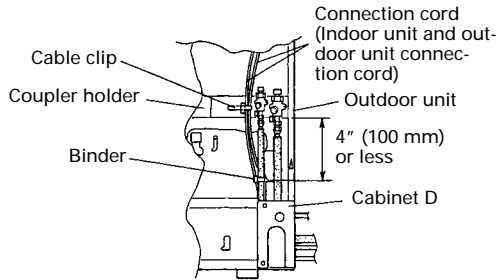

NOTE

- Connector trade size for this unit is 1/2". The connector can be bought at a hardware store. Refer to "How to connect wiring to the terminals" for instructions on connecting depending on the wire type you are using.
- The fuse located in the outdoor unit provides power supply protection and may blow when power is applied if the system has been incorrectly wired.

⚠ CAUTION

■ EXAMPLE OF INCORRECT WIRING (Cooling model)

The following are examples of improper wiring that results in system misoperation. You should confirm that you have wired the units correctly before beginning the test run.

Fig. 42

Problem 1

- Short circuit will occur after approx. 3 minutes and the power circuit fuse blows.

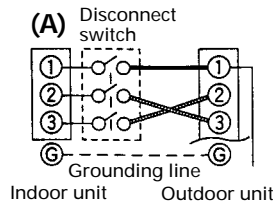

Problem 2

- Air conditioner will not operate.

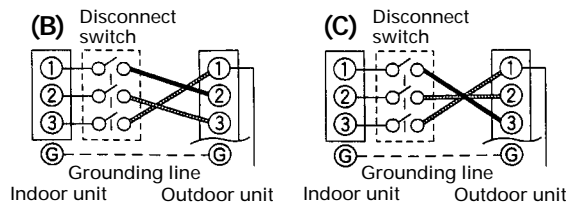

Problem 3

- Compressor will not start; only indoor unit will operate.

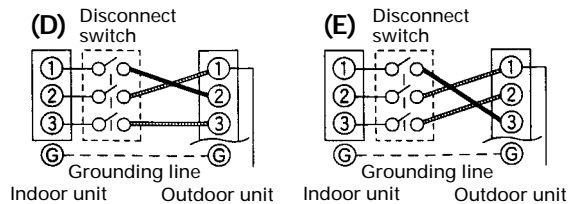

10. POWER

⚠ WARNING

- (1) The rated voltage of this product is 230/208V A.C. 60Hz.
- (2) Before turning on verify that the voltage is within the 187 to 253V range.
- (3) Always use a special branch circuit and install a special receptacle to supply power to the air conditioner.
- (4) Use a circuit breaker and receptacle matched to the capacity of the air conditioner.
- (5) The circuit breaker is installed in the permanent wiring. Always use a circuit that can trip all the poles of the wiring and has an isolation distance of at least 3 mm between the contacts of each pole.
- (6) Perform wiring work in accordance with standards so that the room air conditioner can be operated safely and positively.
- (7) Install a leakage circuit breaker in accordance with the related laws and regulations and electric company standards.

⚠ CAUTION

- (1) The power source capacity must be the sum of the air conditioner current and the current of other electrical appliances. When the current carrying capacity is insufficient, change the circuit capacity.
- (2) When the voltage is low and the air conditioner is difficult to start, contact the power company to have the voltage raised.

11. TEST RUNNING

- Perform test operation and check items 1 and 2 below.
- For the operation method, refer to the operating manual.
- The outdoor unit may not run, depending on the room temperature. In this case, press the TEST RUN button while the air conditioner is running.
(With the transmit section of the remote control unit facing the body, press the TEST RUN button with the tip of a ball point pen.)

Fig. 43

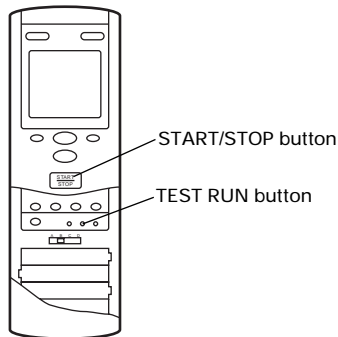

- To end test operation, press the remote control unit START/STOP button.
(When the air conditioner is run by pressing the remote control unit TEST RUN button, the OPERATION and TIMER lamps will simultaneously flash slowly.)

1. INDOOR UNIT

- (1) Is operation of each button on the remote control unit normal?
- (2) Does each lamp light normally?
- (3) Do not air flow direction flap and louvers operate normally?
- (4) Is the drain normal?

2. OUTDOOR UNIT

- (1) Is there any abnormal noise and vibration during operation?
- (2) Will noise, wind, or drain water from the unit disturb the neighbors?
- (3) Is there any gas leakage?

12. FINISHING

- (1) Install the filter guide.
- (2) Install the intake grilles.
- (3) Install side covers A and B (if the unit is installed in a half-concealed orientation, only install side cover A).
- (4) Install the air filters.

13. CUSTOMER GUIDANCE

Explain the following to the customer in accordance with the operating manual:

- (1) Starting and stopping method, operation switching, temperature adjustment, timer, air flow adjustment, and other remote control unit operations.
- (2) Air filter removal and cleaning.
- (3) Give the operating and installation manuals to the customer.

14. REMOTE CONTROL UNIT INSTALLATION

⚠ CAUTION

- (1) Check that the indoor unit correctly receives the signal from the remote control unit, then install the remote control unit holder.
- (2) Select the remote control unit holder selection site by paying careful attention to the following:
Avoid places in direct sunlight.
Select a place that will not be affected by the heat from a stove, etc.

1. REMOTE CONTROL UNIT HOLDER INSTALLATION

Install the remote control unit holder to a wall or pillar with the tapping screws.

Fig. 44

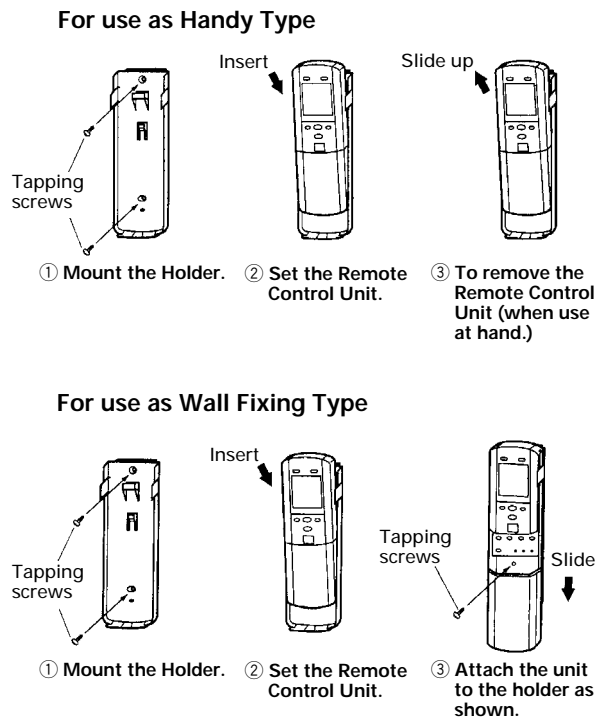

2. REMOTE CONTROL UNIT CODE SWITCHING

Fig. 45

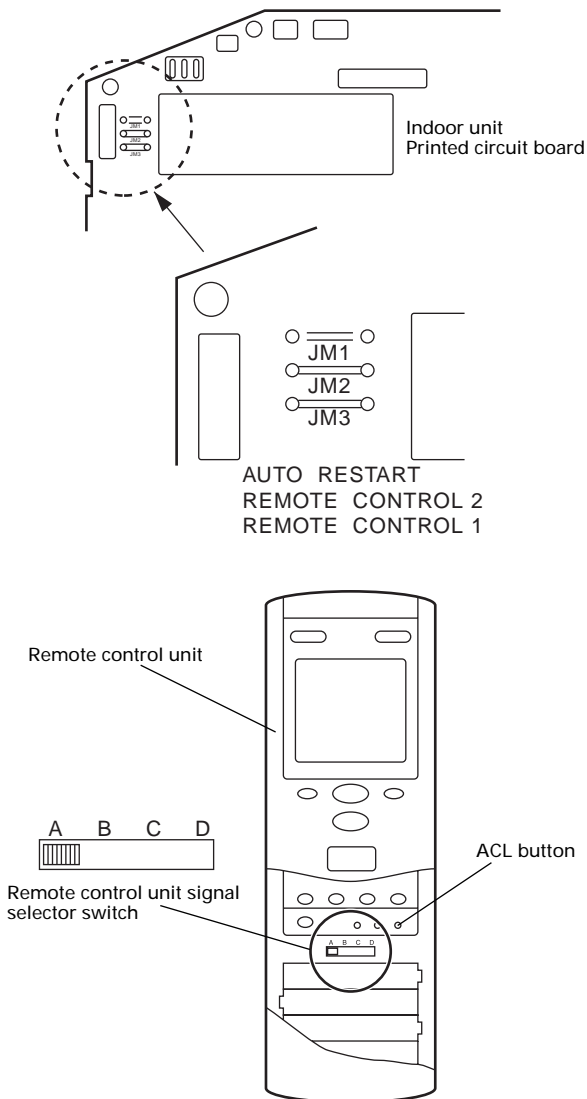

Confirm the remote control unit signal selector switch selection and printed circuit board setting.
If these are not confirmed, the remote control unit cannot be operated for the air conditioner.

Table 8

Jumper wire		Remote control unit signal selector switch
JM 2	JM 3	
Connect	Connect	A (Primary setting)
Connect	Disconnect	B
Disconnect	Connect	C
Disconnect	Disconnect	D

After setting the remote control unit signal selector switch, press the ACL button.

15. FRESH-AIR INTAKE

- (1) Open up the knockout hole for the fresh-air intake, as shown in Fig. 46. (If using half-concealed installation, open up the top knockout hole instead.)

Fig. 46

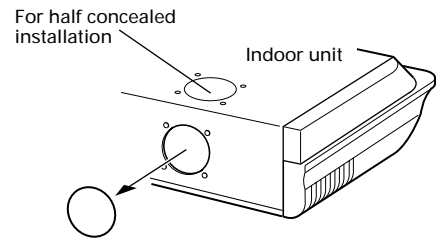

CAUTION

- (1) When removing the cabinet (iron plate), be careful not to damage the indoor unit internal parts and surrounding area (outer case).
- (2) When processing the cabinet (iron plate), be careful not to injure yourself with burrs, etc.

- (2) Fasten the round flange (optional) to the fresh-air intake, as shown in Fig. 47. (If using half-concealed installation, attach to the top.)

Fig. 47

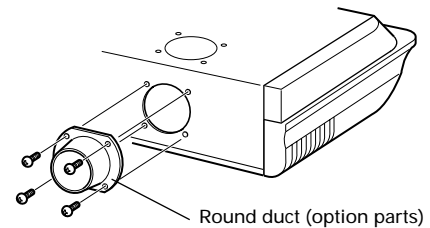

[After completing "2. INDOOR UNIT INSTALLATION" ...]

- (3) Connect the duct to the round flange.
- (4) Seal with a band and vinyl tape, etc. so that air does not leak from the connection.

Fig. 48

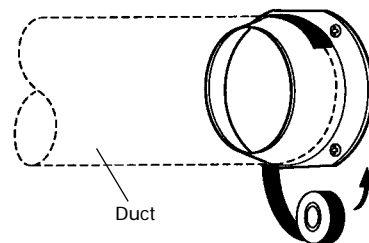

16. AN ERROR DISPLAY

1. INDOOR UNIT

Operation can be checked by lighting and flashing of the display section OPERATION, TIMER and VERTICAL SWING lamps.

Perform judgment in accordance with the following.

Fig. 49

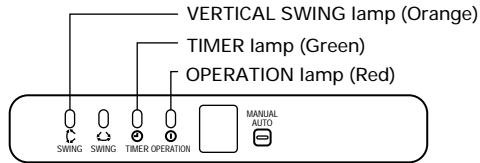

- Test running

When the air conditioner is run by pressing the remote controller test run button, the OPERATION, TIMER and VERTICAL SWING lamps flash slowly at the same time.

- Error

The OPERATION, TIMER and VERTICAL SWING lamps operate as follows (Table 9) according to the error contents.

Table 9

Error display			Error contents
OPERATION lamp	TIMER lamp	VERTICAL SWING lamp	
Blinks	Blinks	Goes off	Model information abnormal (permanent type)
Pulses 4 times	Blinks	Goes off	Drain abnormal (permanent type)
Pulses 6 times	Blinks	Goes off	Indoor fan abnormal
Pulses 2 times	Blinks	Goes off	Room air temperature thermistor open circuited
		Blinks	Room air temperature thermistor shortcircuited
Pulses 3 times	Blinks	Goes off	Piping thermistor open circuited
		Blinks	Piping thermistor short-circuited
Pulses 5 times	Blinks	Goes off	Serial communications abnormal
Blinks	Pulses 2 times	Goes off	Reverse phase wire connection abnormal
Blinks	Pulses 3 times	Goes off	Outdoor heat exchange thermistor open circuited
		Blinks	Outdoor heat exchange thermistor shortcircuited
Blinks	Pulses 6 times	Goes off	High pressure abnormal
Blinks	Pulses 5 times	Goes off	Outdoor discharge thermistor open circuited
		Blinks	Outdoor discharge thermistor shortcircuited
Blinks	Pulses 7 times	Goes off	Discharge temperature abnormal
Blinks	Pulses 4 times	Goes off	Outdoor air temperature thermistor open circuited
		Blinks	Outdoor air temperature thermistor shortcircuited



FUJITSU GENERAL AMERICA, INC.

353 Rt. 46 W.
Fairfield, NJ 07004
888-888-FGAI
www.fujitsugeneral.com