

SPLIT TYPE ROOM AIR CONDITIONER INSTALLATION INSTRUCTION SHEET

(PART NO. 9373598015)

IMPORTANT! Please Read Before Starting

This air conditioning system meets strict safety and operating standards. As the installer or service person, it is an important part of your job to install or service the system so it operates safely and efficiently.

For safe installation and trouble-free operation, you must:

- Carefully read this instruction booklet before beginning.
- Follow each installation or repair step exactly as shown.
- Observe all local, state, and national electrical codes.
- Pay close attention to all danger, warning, and caution notices given in this manual.

WARNING: This symbol refers to a hazard or unsafe practice which can result in severe personal injury or death.

CAUTION: This symbol refers to a hazard or unsafe practice which can result in personal injury and the potential for product or property damage.

- Hazard alerting symbols

Electrical

Safety / alert

If Necessary, Get Help

These instructions are all you need for most installation sites and maintenance conditions. If you require help for a special problem, contact our sales/service outlet or your certified dealer for additional instructions.

In Case of Improper Installation

The manufacturer shall in no way be responsible for improper installation or maintenance service, including failure to follow the instructions in this document.

SPECIAL PRECAUTIONS

When Wiring

ELECTRICAL SHOCK CAN CAUSE SEVERE PERSONAL INJURY OR DEATH. ONLY A QUALIFIED, EXPERIENCED ELECTRICIAN SHOULD ATTEMPT TO WIRE THIS SYSTEM.

- Do not supply power to the unit until all wiring and tubing are completed or reconnected and checked.
- Highly dangerous electrical voltages are used in this system. Carefully refer to the wiring diagram and these instructions when wiring. Improper connections and inadequate grounding can cause accidental injury or death.
- Ground the unit following local electrical codes.
- Connect all wiring tightly. Loose wiring may cause overheating at connection points and a possible fire hazard.

GENERAL

This INSTALLATION INSTRUCTION SHEET briefly outlines where and how to install the air conditioning system. Please read over the entire set of instructions for the indoor and outdoor units and make sure all accessory parts listed are with the system before beginning.

1. TYPE OF COPPER PIPE AND INSULATION MATERIAL

Copper tubing for connecting the outdoor unit to the indoor unit and insulation material is available for purchase locally. When you purchase them, please specify the following.

(1) Deoxidized annealed copper pipe for refrigerant piping as:

Table 1		
	Outer diameter	Thickness
Small pipe	3/8" (9.52 mm)	1/32" (0.8 mm)
Large pipe	3/4" (19.05 mm)	3/64" (1.0 mm)

Cut each pipe to the appropriate length + 12" (30 cm) to 16" (40 cm) to dampen vibration between units.

CAUTION

- Limit the height difference between the indoor and outdoor units to within 99 ft (30 m).
- The maximum length of the piping is 164 ft (50 m). If the units are further apart than this, correct operation cannot be guaranteed.

(2) Foamed polyethylene insulation for copper pipes as required to precise length of piping. Wall thickness of the insulation should not be less than 5/16" (8 mm).

CAUTION

Install heat insulation around both the gas and liquid pipes. Failure to do so may cause water leaks. Use heat insulation with heat resistance above 248 °F. (Reverse cycle model only) In addition, if the humidity level at the installation location of the refrigerant piping is expected to exceed 70%, install heat insulation around the refrigerant piping. If the expected humidity level is 70-80%, use heat insulation that is 5/8" (15 mm) or thicker and if the expected humidity exceeds 80%, use heat insulation that is 13/16" (20 mm) or thicker. If heat insulation is used that is not as thick as specified, condensation may form on the surface of the insulation. In addition, use heat insulation with heat conductivity of 0.045 W/(m·K) or less (at 68 °F).

(3) Use insulated copper wire for field wiring.

CAUTION

Check local electrical codes and regulations before obtaining wire. Also, check any specified instructions or limitations.

When Transporting

Be careful when picking up and moving the indoor and outdoor units. Get a partner to help, and bend your knees when lifting to reduce strain on your back. Sharp edges or thin aluminum fins on the air conditioner can cut your fingers.

When Installing...

...In a Ceiling or Wall

Make sure the ceiling/wall is strong enough to hold the unit's weight. It may be necessary or useful to construct a strong wood or metal frame to provide added support.

...In a Room

Properly insulate any tubing run inside a room to prevent "sweating" that can cause dripping and water damage to walls and floors.

...In Moist or Uneven Locations

Use a raised concrete pad or concrete blocks to provide a solid, level foundation for the outdoor unit. This prevents water damage and abnormal vibration.

...In an Area with High Winds

Securely anchor the outdoor unit down with bolts and a metal frame. Provide a suitable air baffle.

...In a Snowy Area (for Heat Pump-type Systems)

Install the outdoor unit on a raised platform that is higher than drifting snow. Provide snow vents.

When Connecting Refrigerant Tubing

- These instructions are all you need for most installation sites and maintenance conditions. If you require help for a special problem, contact our sales/service outlet or your certified dealer for additional instructions.
- Use the flare method for connecting tubing.
- Apply refrigerant lubricant to the matching surfaces of the flare and union tubes before connecting them, then tighten the nut with a torque wrench for a leak-free connection.
- Check carefully for leaks before starting the test run.

NOTE:

Depending on the system type, liquid and gas lines may be either narrow or wide. Therefore, to avoid confusion the refrigerant tubing for your particular model is specified as either "small" or "large" rather than as "liquid" or "gas".

When Servicing

- Turn the power OFF at the main circuit breaker panel before opening the unit to check or repair electrical parts and wiring.
- Keep your fingers and clothing away from any moving parts.
- Clean up the site after you finish, remembering to check that no metal scraps or bits of wiring have been left inside the unit being serviced.
- After installation, explain correct operation to the customer, using the operating manual.

INSTALLATION PROCEDURE

1 INDOOR UNIT INSTALLATION

The piping can be connected in the five directions indicated by ①, ②, ③, ④, and ⑤ in Fig. 5.

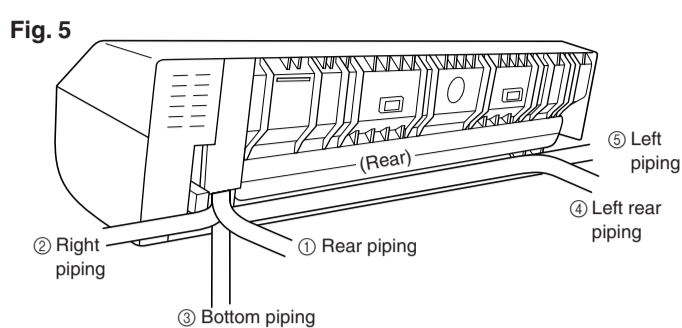

1. INSTALLING THE WALL HOOK BRACKET

[Removing THE WALL HOOK BRACKET]

Remove the wall hook bracket in the following order.

- Open the screw cover and remove the two screws. (Fig. 6)
- Pull off the front cover to the front. (Fig. 7)
- Remove the tapping screws securing the wall hook bracket. (Fig. 8)

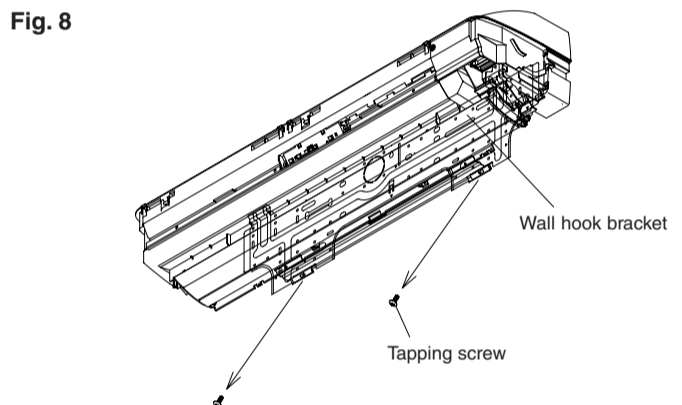
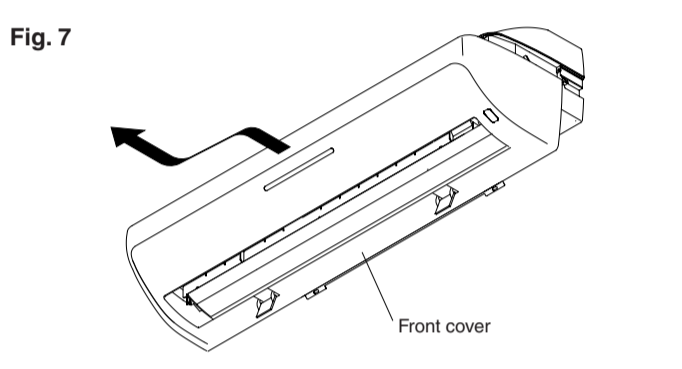
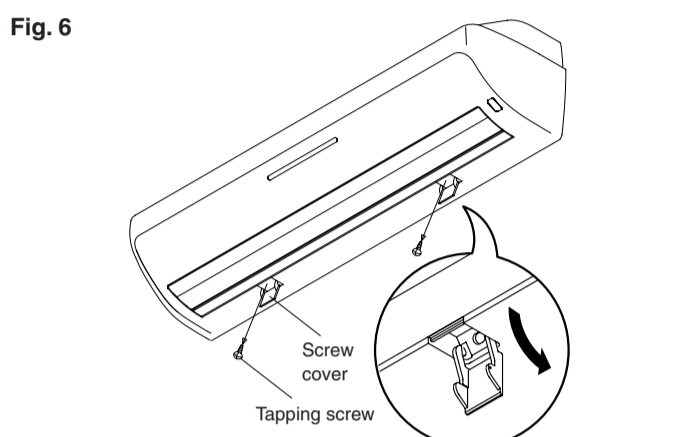

[Installation directly to a wall]

- Before fastening the wall hook bracket to the wall with the screws, level it by tapping the hook at the center of bracket to the wall with the handle of a screwdriver.
- Fasten the wall hook bracket to the wall with 6 or more screws and anchor bolts through the holes near the outer edge of the bracket.
- Do not install the wall hook bracket at only one place or at an angle. For a concrete wall, embed anchor bolts (13/32" (10 mm) dia.) into the wall at the wall hook bracket holes (2-7/16" x 1-1/16" (11 x 43 mm) dia.). Allow the anchor bolts to stick out at least 15/32" (12 mm) from the wall. (Fig. 10) Install the unit to the anchor bolts with nuts through the wall hook bracket. Use 2 bolts for concrete wall and 4 bolts for blister concrete wall.
- Finally tighten the bolts and tapping screws after confirming, using the level indicator, that the clamp is horizontal.

WARNING

- Install the wall hook bracket so that it is correctly positioned horizontally and vertically. If the wall hook bracket is tilted or the installation point of the indoor unit is not level, water will drip to the floor.
- As the weight of the indoor unit is 33 to 40 lbs (15 to 18 kg), it should be installed after properly examining the place where it is intended to be installed. If the place is not strong enough, a plank or girder should be used to make the place sufficiently strong so that the wall can support the weight.

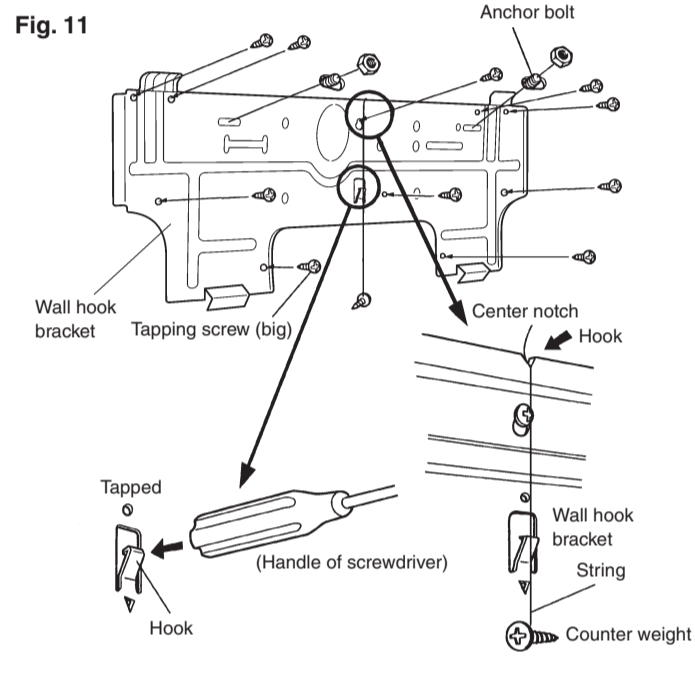
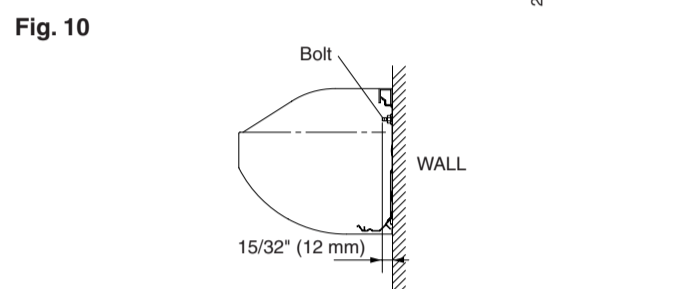
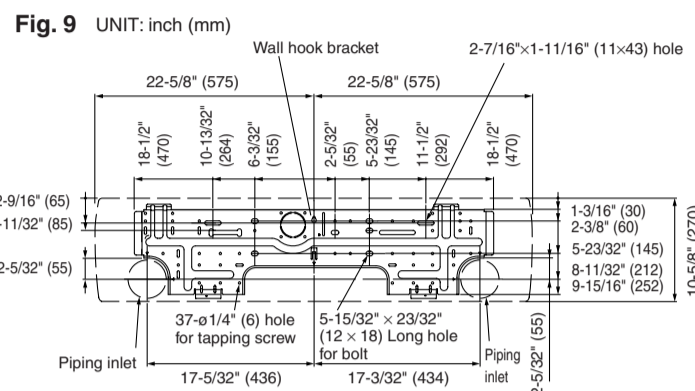

2. CUTTING THE HOLE IN THE WALL FOR THE CONNECTING PIPING

WARNING

If the wall pipe is not used, the cord interconnecting the indoor and outdoor units may touch metal and cause electric leakage.

- Cut a 3-15/16" (100 mm) diameter hole in the wall at the position shown in Fig. 12.
- When cutting the wall hole at the inside of the installation frame, cut the hole to a point of intersection of center marks. When cutting the wall hole at the outside of the installation frame, cut the hole at least 13/32" (10 mm) below less.
- Cut the hole so that the outside end is lower (3/16" to 13/32" (5 to 10 mm)) than the inside end.
- Always align the center of the wall hole. If misaligned, water leakage will occur.
- Cut the wall pipe to match the wall thickness, stick it into the wall cap, fasten the cap with vinyl tape, and stick the pipe through the hole. (The connection pipe is supplied in the installation set.) (Fig. 12).
- For ② left piping and ③ right piping, cut the hole a little lower so that drain water will flow freely (Fig. 12).

Fig. 12

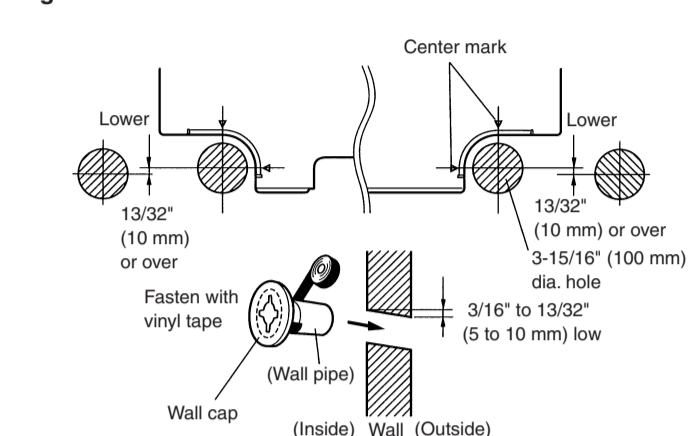

3. ATTACH THE DRAIN HOSE

CAUTION

Insert the drain hose and drain cap into the drain port, making sure that it comes in contact with the back of the drain port, and then mount it. If the drain hose is not connected properly, leaking will occur.

- Attach the Insulation (Drain hose) to the drain hose.

Fig. 13

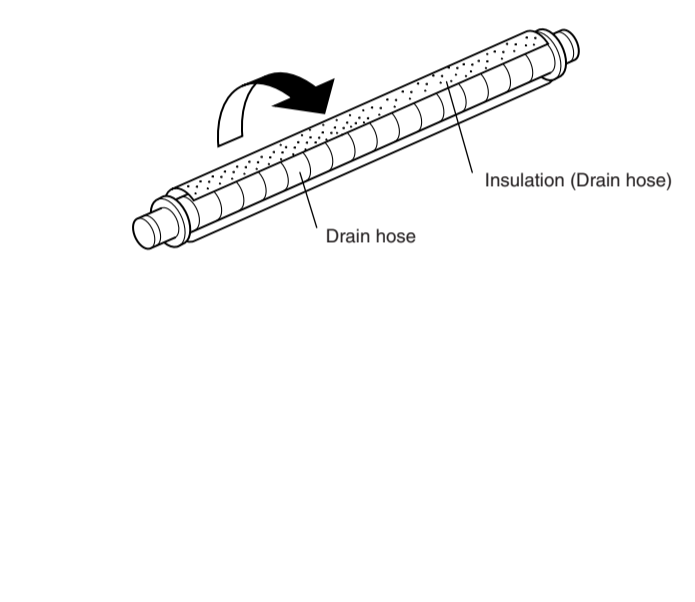

2. ADDITIONAL MATERIALS REQUIRED FOR INSTALLATION

- Refrigeration (armored) tape
- Insulated staples or clamps for connecting wire (See your local electrical codes.)
- Putty
- Refrigeration lubricant
- Clamps or saddles to secure refrigerant piping

3. OPERATING RANGE

	Table 2		
	Temperature	Indoor air intake	Outdoor air intake
Cooling	Maximum	90°F DB, 73°F WB	115°F DB
	Minimum	65°F DB, 57°F WB	70°F DB
Heating	Maximum	86°F DB, -WB	75°F DB, 65°F WB
	Minimum	-DB, -WB	17°F DB, -WB

ELECTRICAL REQUIREMENT

Always make the air conditioner power supply a special branch circuit and provide a special switch and receptacle. Do not extend the power cord.

CAUTION		
MAXIMUM OVERCURRENT PROTECTION (TIME DELAY FUSE OR HACR TYPE CIRCUIT BREAKER)	35 A	
MINIMUM CIRCUIT AMPACITY	30 A	

Fig. 1

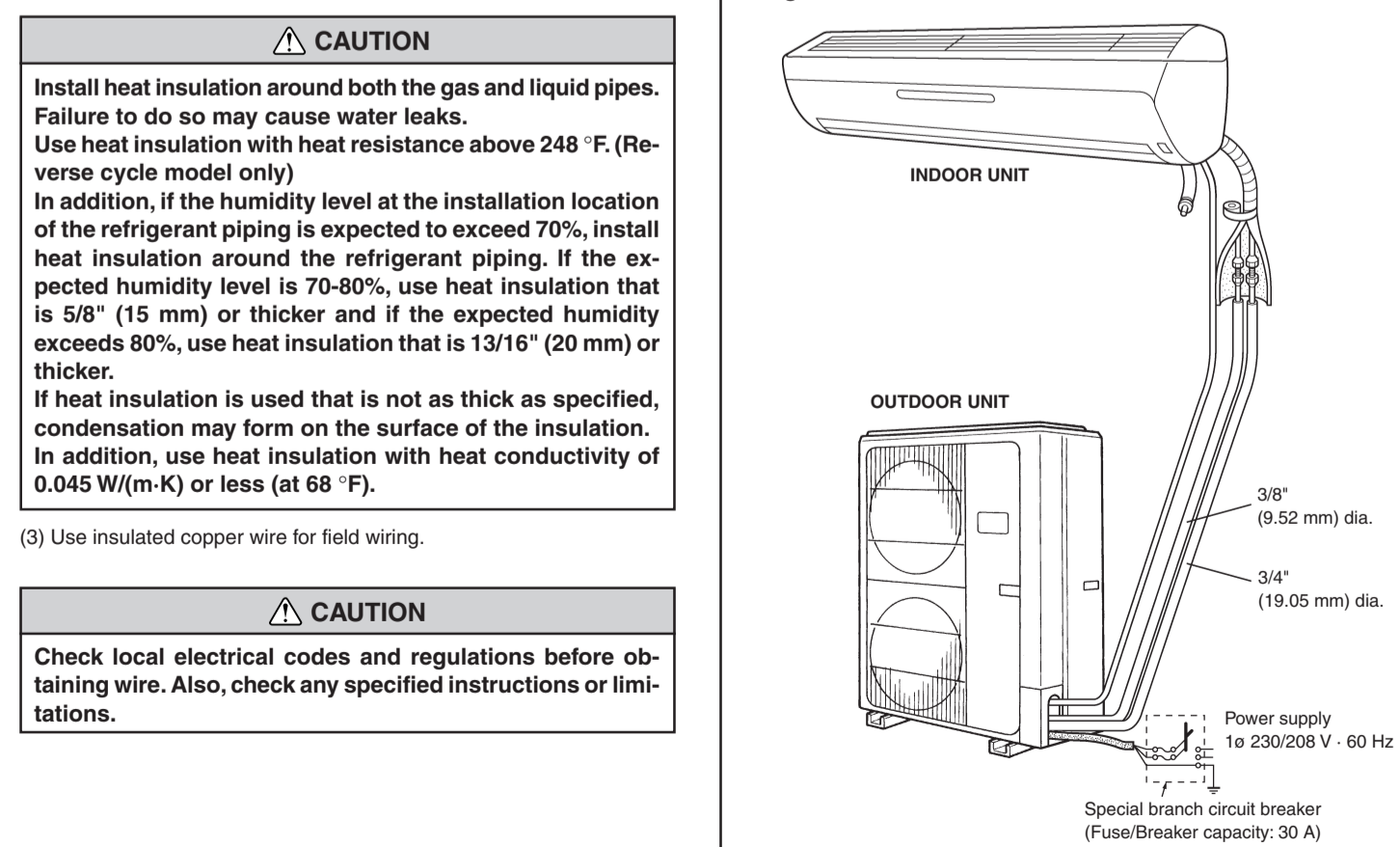

(3) Use insulated copper wire for field wiring.

CAUTION

Check local electrical codes and regulations before obtaining wire. Also, check any specified instructions or limitations.

SELECTING THE MOUNTING POSITION

WARNING

Install at a place that can withstand the weight of the indoor and outdoor units and install positively so that the units will not topple or fall.

CAUTION

- Do not install where there is the danger of combustible gas leakage.
- Do not install near heat sources.
- If children under 10 years old may approach the unit, take preventive measures so that they cannot reach the unit.

Decide the mounting position with the customer as follows:

1. INDOOR UNIT

- Install the indoor unit level on a strong wall which is not subject to vibration.
- The inlet and outlet ports should not be obstructed: the air should be able to blow all over the room.
- Do not install the unit where it will be exposed to direct sunlight.
- Install the unit where connection to the outdoor unit is easy.
- Install the unit where the drain pipe can be easily installed.
- Take servicing, etc. into consideration and leave the spaces shown in Fig. 2. Also install the unit where the filter can be removed.

Fig. 2

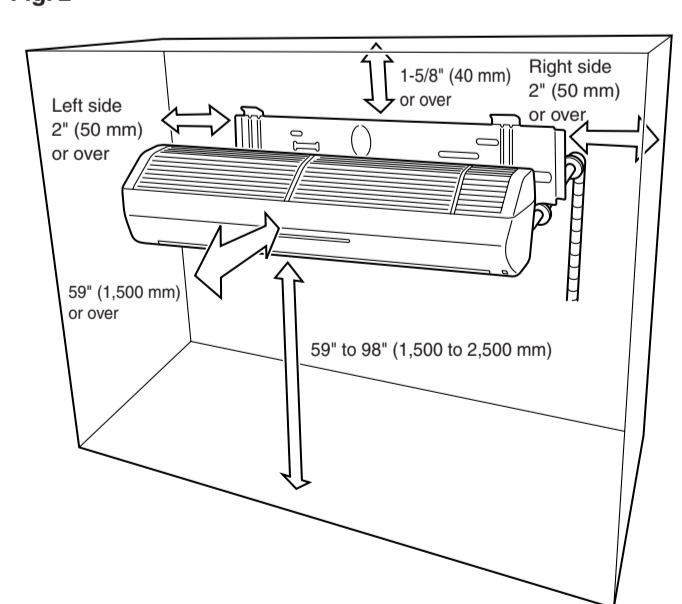

CAUTION

If there is a section of the ceiling that protrudes, mount in a position that allows for 1-5/8" (40 mm) or more of space between the unit and the protrusion.

2. OUTDOOR UNIT

WARNING

- Install the unit where it will not be tilted by more than 5°.
- When installing the outdoor unit where it may be exposed to strong wind, fasten it securely.

(1) Leave the spaces indicated for good air flow (Fig. 4).

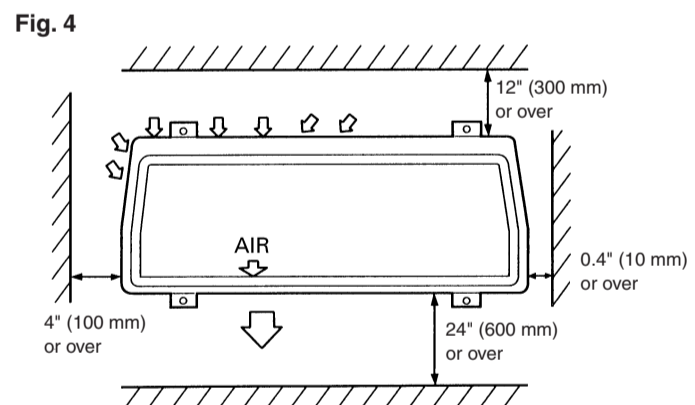

- If possible, do not install the unit where it will be exposed to direct sunlight. (If necessary, install a blind that does not interfere with the air flow.)
- The inlet and outlet ports should not be obstructed: the air should be able to blow all over the room.
- Do not install the unit near a source of heat, steam, of flammable gas.
- During heating operation, drain water flows from the outdoor unit. Therefore, install the outdoor unit in a place where the drain water flow will not be obstructed. (Reverse cycle model only.)
- Do not install the unit where a strong wind blows or where it is very dusty.
- Do not install the unit where people pass.
- Install the outdoor unit in a place where it will be free from being dirty or getting wet by rain as much as possible.
- Install the unit when connection to the indoor unit is easy.

Fig. 4



CAUTION

If there is a section of the ceiling that protrudes, mount in a position that allows for 1-5/8" (40 mm) or more of space between the unit and the protrusion.

STANDARD ACCESSORIES

The following installation accessories are supplied. Use them as required.

INDOOR UNIT ACCESSORIES

Name and Shape	Qty	Use
Wall hook bracket	1	For indoor unit installation
Remote control unit	1	Use for air conditioner operation
Battery (penlight)	2	For remote control unit
Remote control unit holder	1	Use as remote control unit holder
Drain hose	1	For indoor unit installation
Insulation (Drain hose)	1	For drain hose installation
Tapping screw (big) (ø4 x 20)	12	For wall hook bracket installation
Tapping screw (small) (ø3 x 12)	2	For remote control unit holder installation

OUTDOOR UNIT ACCESSORIES

Power cap	1	For power cord installation
Auxiliary pipe assembly	1	For connecting the piping
Edge cover	1	For edge protection
Tapping screw	2	• For cabinet A and cabinet D mounting (1) • Spare (1)
Binder	1	For power supply cord binding
Putty	1	For sealing
Coupler heat insulation	1	For outdoor side pipe joint

2 OUTDOOR UNIT INSTALLATION

1. OUTDOOR UNIT PROCESSING

When the outdoor unit will be exposed to strong wind, fasten it with bolts or wire at the four places indicated by the arrows. (Fig. 24)

Fig. 24

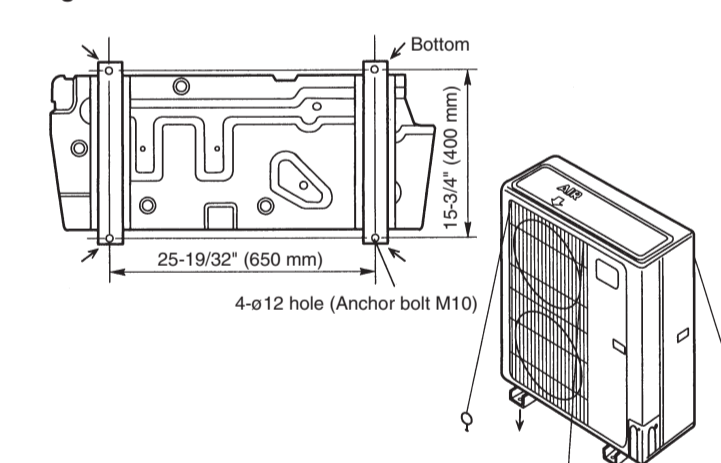

2. OUTDOOR UNIT CONNECTION CORD AND PIPE CONNECTION PREPARATION

(1) Piping and connection cord mounting direction (4-way mounting possible).

Fig. 25

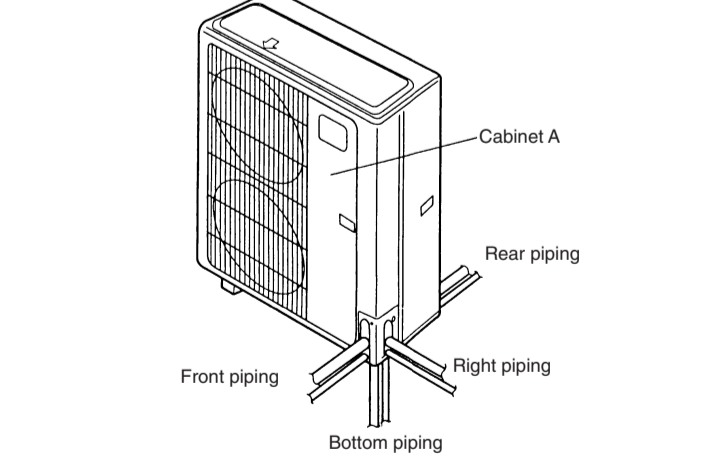

(2) Remove outdoor unit cabinet A and cabinet D.

Fig. 26

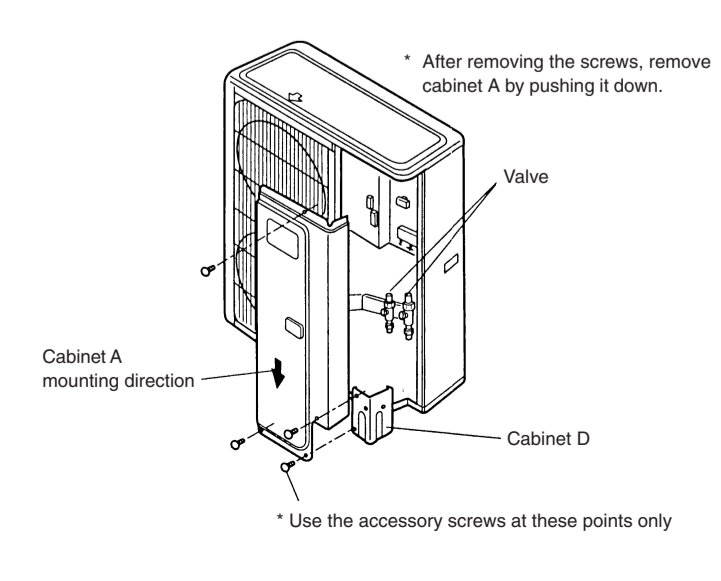

[For ① Rear piping, ② Right piping, ③ Bottom piping]

- Mount the drain hose to the drain port on the right side.

Fig. 14

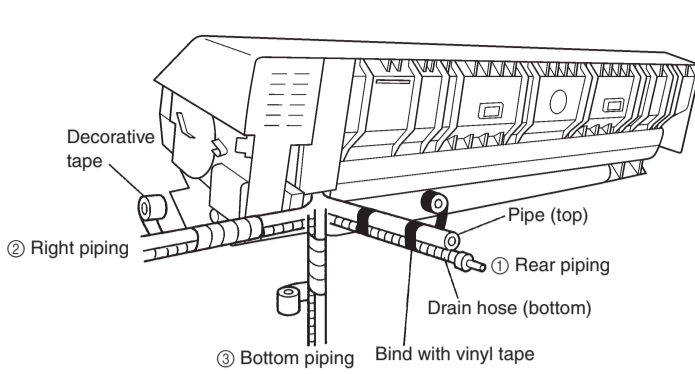

[For ④ Left rear piping, ⑤ Left piping]

- Remove the drain cap and mount to the drain port on the right side.
- Mount the drain hose to the drain port on the left side.

Fig. 15

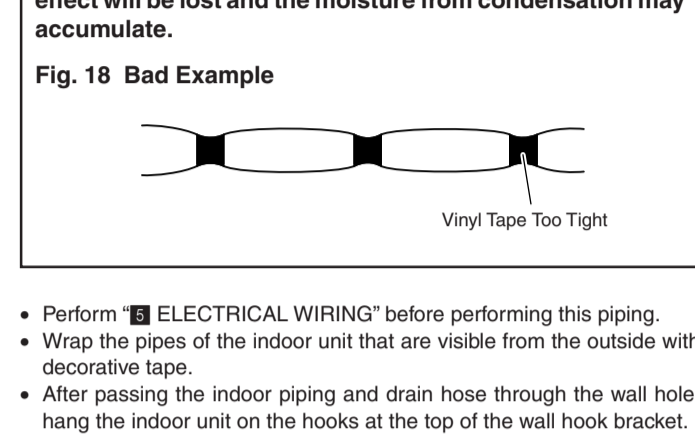

4. CUT-OUT FOR PIPING ON FRONT COVER

[For ② Right piping, ③ Bottom piping, ⑤ Left piping]

- Use a metal shears or other cutting tool to cut along the groove in the thin metal for the piping that will coming out of the front cover.

Fig. 16

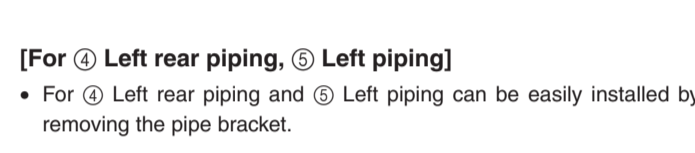

5. FORMING THE DRAIN HOSE AND PIPE

CAUTION

- Do not remove the flare nut from the indoor unit pipe until immediately before connecting the connection pipe.
- To prevent breaking of the pipe, avoid sharp bends. Bend the pipe with a radius of curvature of 6" (150 mm) or over.
- If the pipe is bent repeatedly at the same place, it will break.

Removing the pipe bracket:

Remove the two tapping screws holding the pipe bracket (Fig. 20).

Fig. 20

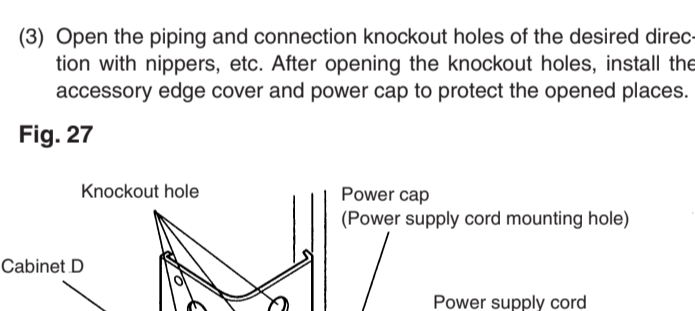

(3) Open the piping and connection knockout holes of the desired direction with nippers, etc. After opening the knockout holes, install the accessory edge cover and power cap to protect the opened places.

Fig. 27



(4) Connect the piping and power supply cord from the mounting holes.

Fig. 28

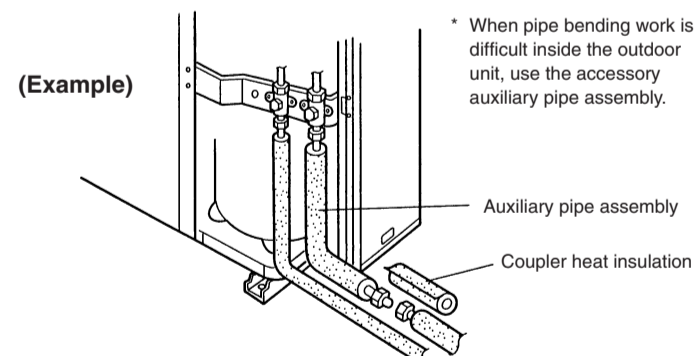

3 CONNECTING THE PIPING

CAUTION

The maximum piping lengths of this product are shown in "GENERAL". If the units are further apart than this, correct operation cannot be guaranteed.

1. FLARE PROCESSING

- Cut the connection pipe with pipe cutters so that the pipe is not deformed.
- Holding the pipe downward so that cuttings cannot enter the pipe and remove the burrs.
- Remove the flare nut from the indoor unit pipe and outdoor unit and assemble as shown in (Table 3) and insert the flare nut onto the pipe, and flare with a flaring tool.
- Check if the flared part "L" (Fig. 29) is spread uniformly and that there are no cracks.

Table 3

Pipe	Flare nut
Small pipe	Small (width across flats 7/8" (22 mm))
Large pipe	Large (width across flats 1-13/32" (36 mm))

Fig. 29

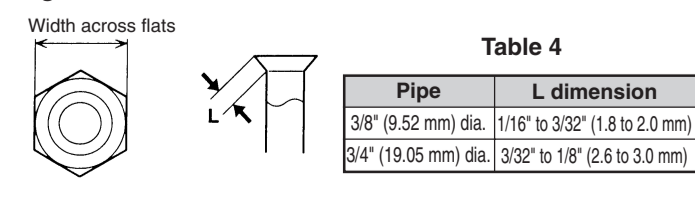

- For ① Left rear piping and ⑤ Left piping, preset the end of the pipe to the dimensions shown in Fig. 21 and form the connection pipe.
- Bend the connection piping at a bend radius of at least 6" (150 mm) and position it no more than 1-31/32" (50 mm) from the wall.

Fig. 21

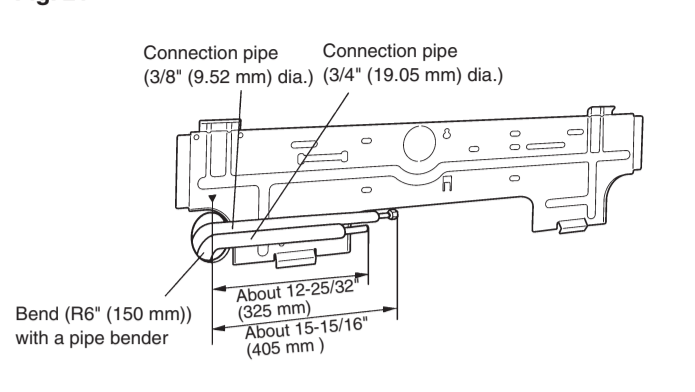

- Weld the 3/4" (19.05 mm) diameter connection pipe to the outdoor unit pipe. Do not join by flaring.
- Piping work can be made easier by laying out, shaping, and temporarily fastening the connection pipe and connection cord as shown in Fig. 22 beforehand.

Fig. 22 (Left rear piping)

VACUUMING AND ADDITIONAL CHARGE

1. VACUUM

- Vacuum inside the indoor unit and the piping to a pressure of 1.5 mmHg abs or less from the charging valve with a vacuum pump.
- After vacuuming inside the indoor unit and the piping, remove the cap of the two valves.
- Open the handle of the two valves from the closed state (Table 7).
- Tighten the cap of the two valves to the specified torque.

Table 6

	Tightening torque	
	Large valve	Small valve
Handle	1.47 N·m (15 kgf·cm) or less	
Cap	14.7 to 19.6 N·m (150 to 200 kgf·cm)	

Table 7

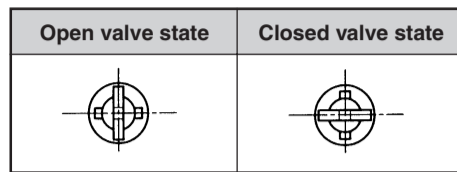

* If the handle is not fully open, performance will drop and an abnormal sound will be generated.

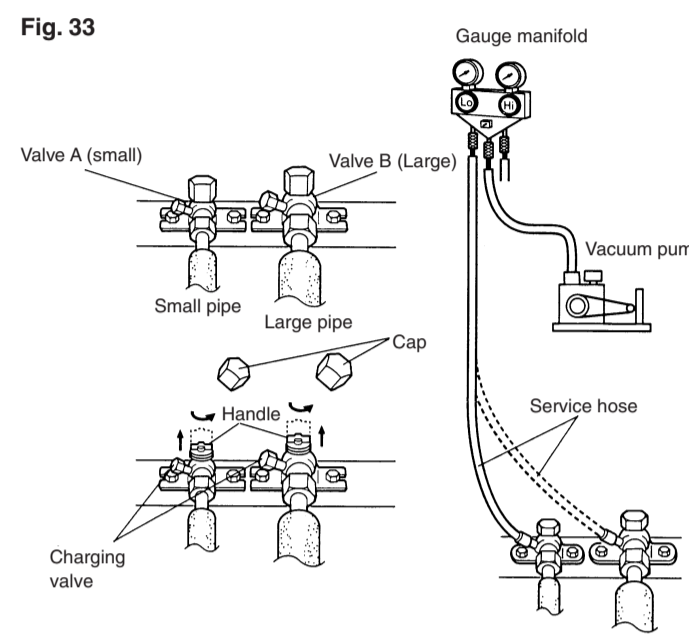

2. ADDITIONAL CHARGE

Refrigerant suitable for a piping length of 25 ft (7.5 m) is charged in the outdoor unit at the factory. When the piping is longer than 25 ft (7.5 m), additional charging is necessary. For the additional amount, see the table below.

Table 8

Pipe length Model type	25 ft (7.5 m)	33 ft (10 m)	66 ft (20 m)	99 ft (30 m)	132 ft (40 m)	164 ft (50 m)	oz/ft (g/m)
	36,000 BTU class	None (50 g)	1.8 oz (50 g)	8.9 oz (250 g)	15.9 oz (450 g)	22.9 oz (650 g)	30.0 oz (850 g)

TEST RUNNING

- Perform test operation and check items 1 and 2 below.
- For the operation method, refer to the operating manual.
- The outdoor unit may not run, depending on the room temperature. In this case, the 'TEST RUN' signal is received during air conditioner operation (use a metallic object to short the two metal contacts under the battery compartment lid and send the 'TEST RUN' signal from the remote control unit).

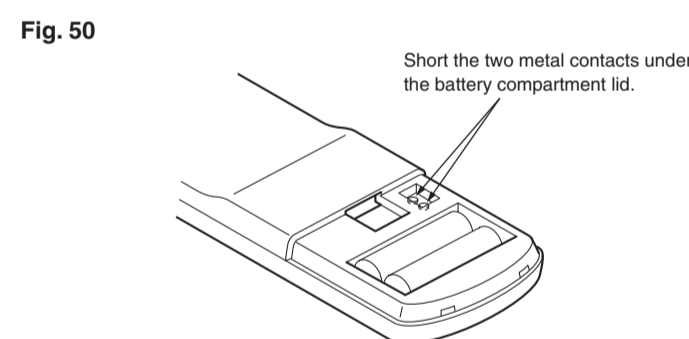

1. INDOOR UNIT

Operation can be checked by lighting and flashing of the display section OPERATION and TIMER lamps. Perform judgement in accordance with the following.

- Test running
 - When the air conditioner is run by pressing the remote control unit test run button, the OPERATION and TIMER lamps flash slowly at the same time.
- Error
 - The OPERATION, TIMER and SWING lamps operate as follows (Table 9) according to the error contents.

Table 9

Error contents	OPERATION lamp (RED)	TIMER lamp (YELLOW)	SWING lamp (ORANGE)
Indoor EEPROM abnormal	○	○	×
Outdoor EEPROM abnormal	○	○	○
Indoor room temperature sensor open	(2 times) ●	○	×
Indoor room temperature sensor shortcircuited	(2 times) ●	○	○
Indoor heat exchanger temperature sensor open	(3 times) ●	○	×
Indoor heat exchanger temperature sensor shortcircuited	(3 times) ●	○	○
Float switch operated	(4 times) ●	○	×
Indoor signal abnormal	(5 times) ●	○	×
Outdoor signal abnormal	(5 times) ●	○	○
Indoor fan abnormal	(6 times) ●	○	×
Outdoor power source connection abnormal	○	(2 times) ●	×
Outdoor heat exchanger temperature sensor open	○	(3 times) ●	×
Outdoor heat exchanger temperature sensor shortcircuited	○	(3 times) ●	○
Outdoor temperature sensor open	○	(4 times) ●	×
Outdoor temperature sensor shortcircuited	○	(4 times) ●	○
Outdoor discharge pipe temperature sensor open	○	(5 times) ●	×
Outdoor discharge pipe temperature sensor shortcircuited	○	(5 times) ●	○
Outdoor high pressure abnormal	○	(6 times) ●	×
Outdoor discharge pipe temperature abnormal	○	(7 times) ●	×

○: 0.1s ON/0.1s OFF (flash) ×: OFF
●: 0.5s ON/0.5s OFF (flash)

ELECTRICAL WIRING

WARNING

- Before starting work, check that power is not being supplied to indoor unit and the outdoor unit.
- Match the terminal block numbers and connection cord colors of the indoor unit and the outdoor unit. Erroneous wiring may cause burning of the electric parts.
- Connect the connection cords firmly to the terminal block. Imperfect installation may cause a fire.
- Always fasten the outside covering of the connection cord with the cord clamp. (If the insulator is chafed, electric leakage may occur.)
- Always connect the ground wire.

2. OUTDOOR UNIT

When the outdoor temperature drops, the outdoor unit's fans may switch to low speed, or one of the fans may stop intermittently.

ERROR

The LED lamps operate as follows (Table 10) according to the error contents.

Table 10

Error contents	LED1	LED2	LED3	LED4	LED5	LED6
Signal abnormal	—	—	×	○	×	×
Indoor unit abnormal	—	—	×	×	○	×
Discharge pipe temperature abnormal	—	—	×	×	×	○
Outdoor heat exchanger temperature abnormal	—	—	×	×	○	○
Outdoor temperature abnormal	—	—	×	○	×	○
Power source connection error	—	—	○	×	×	×
EEPROM abnormal	—	—	○	○	○	○
Outdoor high pressure abnormal	○	—	—	—	—	—
Discharge pipe temperature abnormal	○	—	—	—	—	—

○: 0.5s ON/0.5s OFF (flash) ×: OFF
●: 0.1s ON/0.1s OFF (flash) —: Indefinite

When the fault is cleared, the LED lamp goes off. However, for discharge pipe temperature abnormal and high pressure abnormal, the LED lamp lights continuously for 24 hours, as long as the power is not turned off.

CHECK ITEMS

1. INDOOR UNIT

- Is operation of each button on the remote control unit normal?
- Does each lamp light normally?
- Do not air flow direction louvers operate normally?
- Is the drain normal?
- Is there any abnormal noise and vibration during operation?

2. OUTDOOR UNIT

- Is there any abnormal noise and vibration during operation?
- Will noise, wind, or drain water from the unit disturb the neighbors?
- Is there any gas leakage?

- Do not operate the air conditioner in the test running state for a long time.
- For the operation method, refer to the operating manual and perform operation check.

HOW TO CONNECT WIRING TO THE TERMINALS

A. For solid core wiring (or F-cable)

- Cut the wire end with a wire cutter or wire-cutting pliers, then strip the insulation to about 15/16" (25 mm) to expose the solid wire.
- Using a screwdriver, remove the terminal screw(s) on the terminal board.
- Using pliers, bend the solid wire to form a loop suitable for the terminal screw.
- Shape the loop wire properly, place it on the terminal board and tighten securely with the terminal screw using a screwdriver.

B. For strand wiring

- Cut the wire end with a wire cutter or wire-cutting pliers, then strip the insulation to about 3/8" (10 mm) to expose the strand wiring.
- Using a screwdriver, remove the terminal screw(s) on the terminal board.
- Using a round terminal fastener or pliers, securely clamp a round terminal to each stripped wire end.
- Position the round terminal wire, and replace and tighten the terminal screw using a screwdriver.

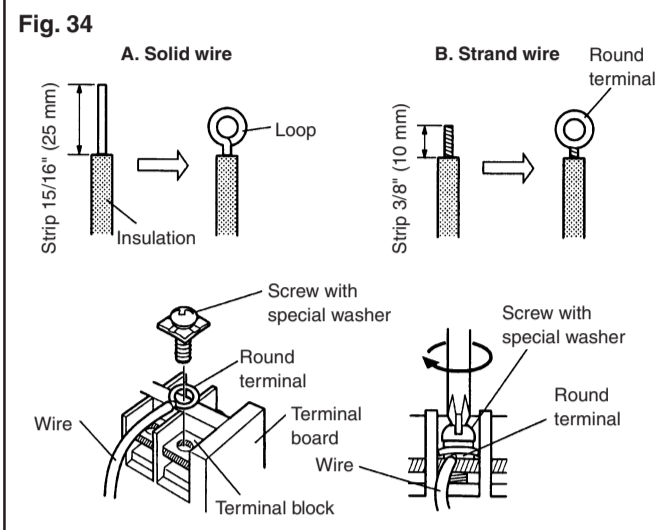

1. INDOOR UNIT SIDE

- Remove the service cover (Fig. 35).
- Remove the control box cover (Fig. 36).

Remove the service cover

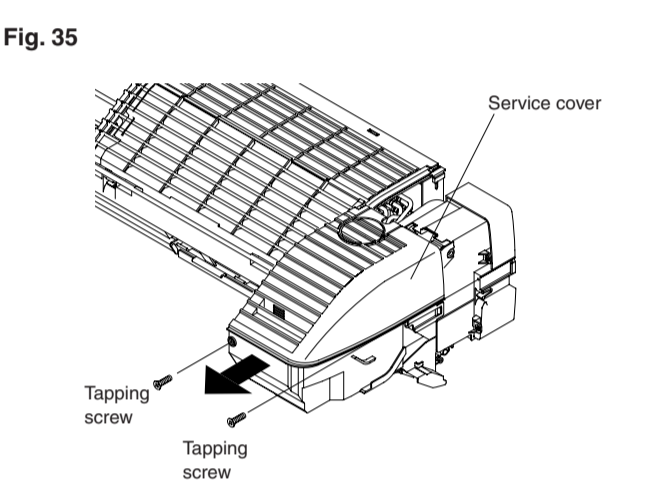

Removing the control box cover

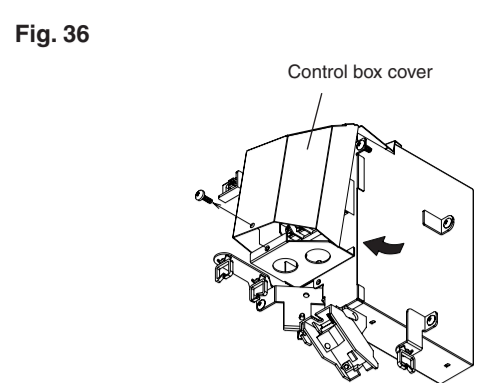

- Process the end of the connection cords to the dimension shown in Fig. 37 and bend the end of each wire as shown.
- Connect the end of the connection cord fully into the terminal board and fasten with the screw.

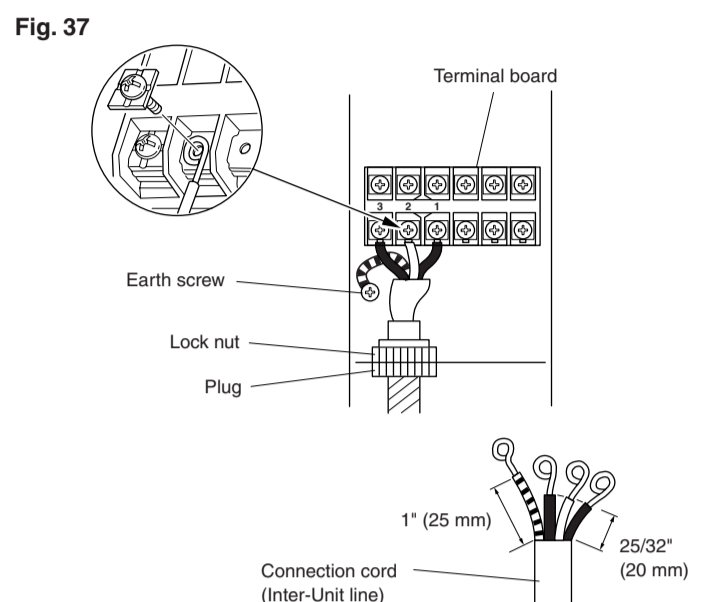

WIRING SYSTEM DIAGRAM

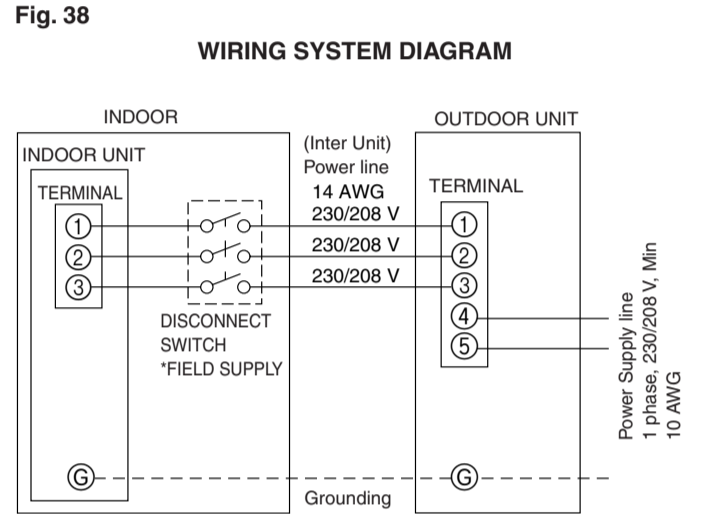

2. OUTDOOR UNIT SIDE

- Remove the plugs on the Cabinet D.
- Temporarily mount the conduit tubes on the Cabinet D.
- Properly connect both the power supply and inter-unit lines to the corresponding terminals on the terminal board. Refer to the wiring system diagram in Fig. 38.
- Ground the unit in accordance with local codes.
- Be sure to size each wire allowing several inches longer than the required length for wiring.
- Use lock nuts to secure the conduit tube.

Fig. 39

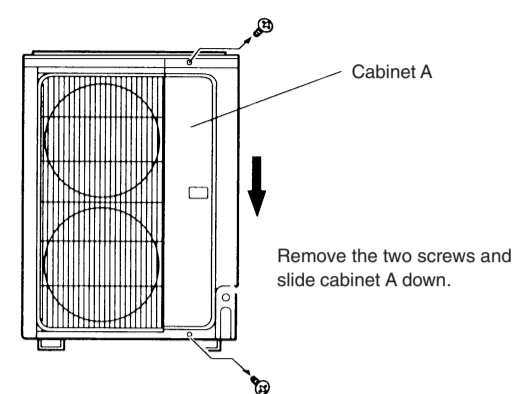

Fig. 40

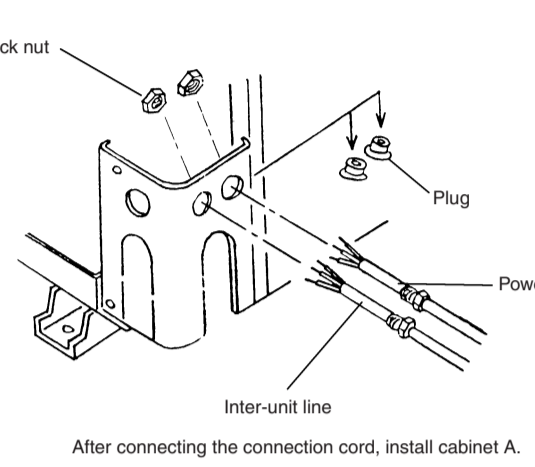
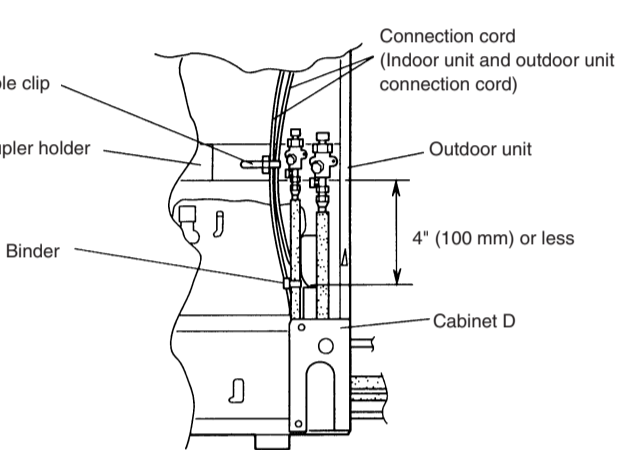

Fig. 41



FINISHING

1. CONNECTION PIPE, CORD AND DRAIN HOSE

- Insulate between pipes.
 - For ① Rear, ② Right, and ③ Bottom piping, overlap the connection pipe heat insulation and indoor unit pipe heat insulation and bind them with vinyl tape so that there is no gap.
 - For ④ Left rear and ⑤ Left piping, butt the connection pipe heat insulation and indoor unit pipe heat insulation together and bind them with vinyl tape so that there is no gap.

Fig. 42

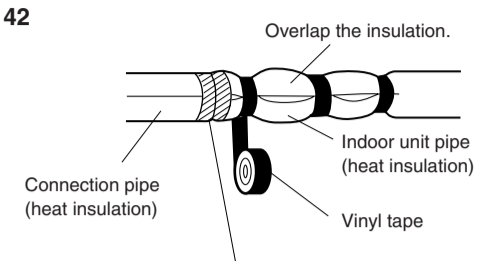
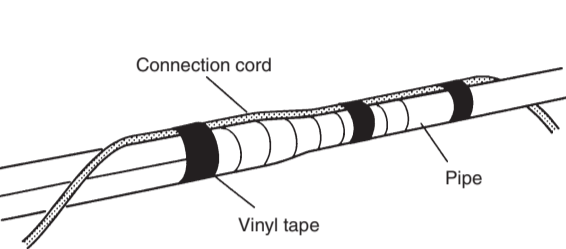

Fig. 43

- For ② Left rear and ③ Left piping, wrap the area which accommodates the rear piping housing section with cloth tape.
- For ④ Left rear and ⑤ Left piping, bind the connection cord to the top of the pipe with vinyl tape.

Fig. 44



Check that:

- The top and bottom hooks are hooked firmly and the indoor unit does not move to the front and rear or left and right.
- The indoor unit is accurately positioned horizontally and vertically.
- When connected from the left rear, the drain hose is at the bottom left of the wall pipe.

Fig. 45

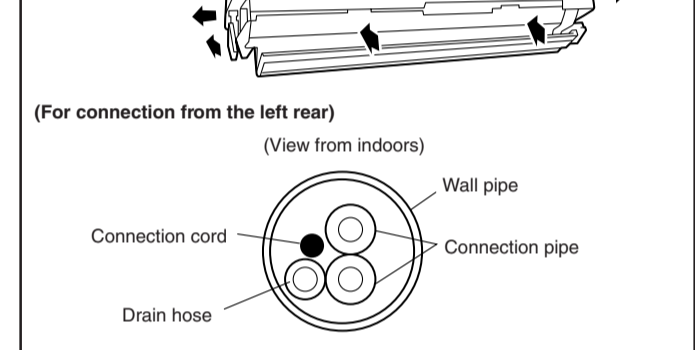

- Temporarily fasten the connection cord along the connection pipe with vinyl tape. (Wrap to about 1/3 the width of the tape from the bottom of the pipe so that water does not enter.)
- Fasten the connection pipe to the outside wall with a saddle, etc.
- Fill the gap between the outside wall pipe hole and the pipe with sealer so that rain water and wind cannot blow in.

Fig. 46

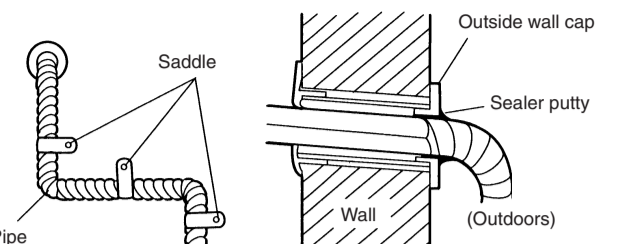
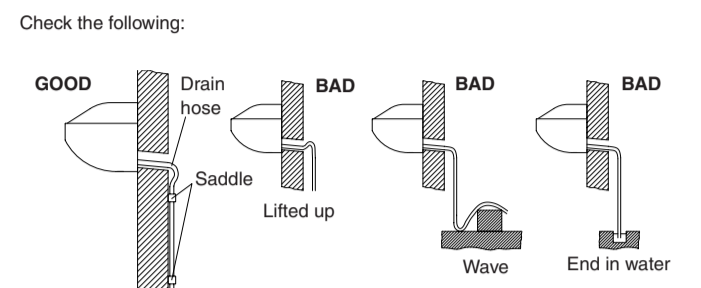

Fig. 47



2. INSTALLING FRONT COVER

- Carefully attach the front cover to the diffuser on the front of the body of the indoor unit.
- Secure the lower section of the front cover with tapping screws in two locations and close the screw cover.
- Push in the following hooks from the outside: front hook, 3 locations; side hook, 2 locations; under hook, 1 location.
- The last step is to push in the hook above the blower outlet.

Fig. 48

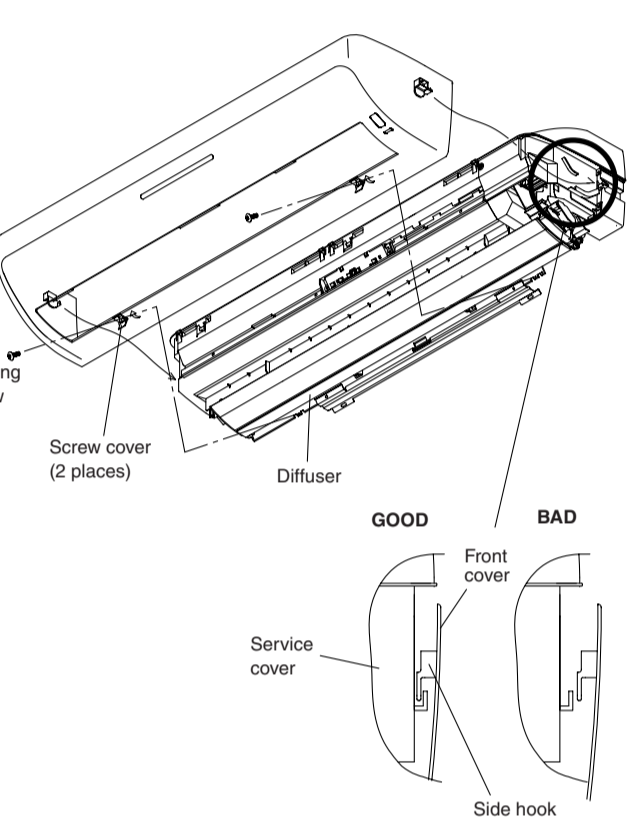
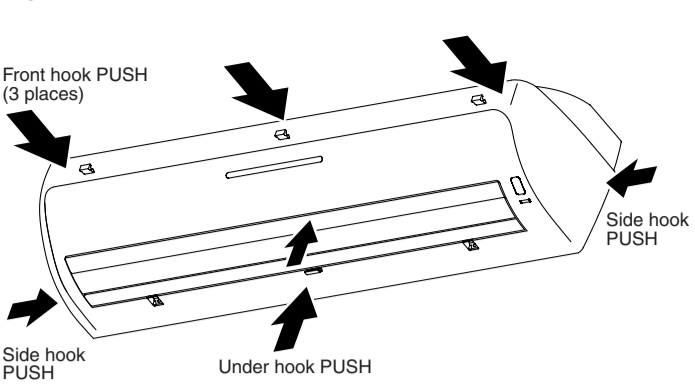

Fig. 49



POWER

WARNING

- The rated voltage of this product is 230/208 V A.C. 60 Hz.
- Before turning on the verify that the voltage is within the 187 V to 253 V range.
- Always use a special branch circuit and install a special receptacle to supply power to the air conditioner.
- Use a circuit breaker and receptacle matched to the capacity of the air conditioner.
- The circuit breaker is installed in the permanent wiring. Always use a circuit that can trip all the poles of the wiring and has an isolation distance of at least 1/8" (3 mm) between the contacts of each pole.
- Perform wiring work in accordance with standards so that the air conditioner can be operated safely and positively.
- Install a leakage circuit breaker in accordance with the related laws and regulations and electric company standards.

CAUTION

- The power source capacity must be the sum of the air conditioner current and the current of other electrical appliances. When the current carrying capacity is insufficient, change the circuit capacity.
- When the voltage is low and the air conditioner is difficult to start, contact the power company to have the voltage raised.

REMOTE CONTROL UNIT INSTALLATION

CAUTION

- Check that the indoor unit correctly receives the signal from the remote control unit, then install the remote control unit holder.
- Select the remote control unit holder selection site by paying careful attention to the following: Avoid places in direct sunlight. Select a place that will not be affected by the heat from a stove, etc.

1. REMOTE CONTROL UNIT HOLDER INSTALLATION

- Install the remote control unit with a distance of 23 ft (7 m) between the remote control unit and the photocell as the criteria. However, when installing the remote control unit, check that it operates positively.
- Install the remote control unit holder to a wall, pillar, etc. with the tapping screw (Fig. 51).

Fig. 51

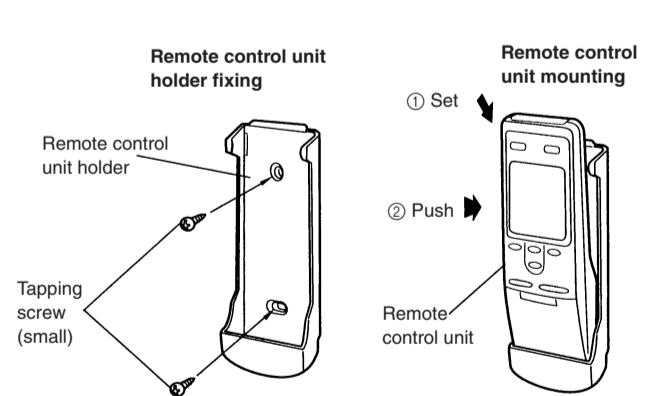

2. SWITCHING REMOTE CONTROL UNIT SIGNAL CODES

Air conditioner settings

Fig. 52

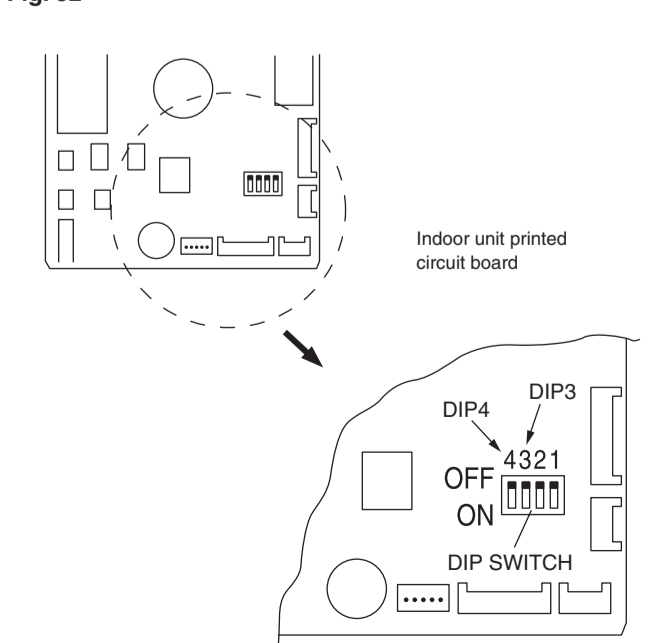

Remote control unit settings

- Press the START/STOP button and display only the clock.

Fig. 53



- Press the MASTER CONTROL button continuously for more than five seconds to display the current signal code.

Fig. 54

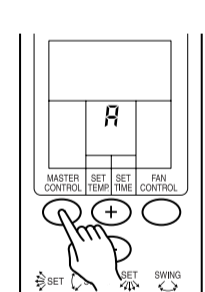

- Change the signal code with the R-B-C-D button.

Fig. 55

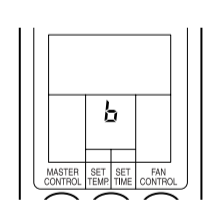

- Press the MASTER CONTROL button again to return to the clock display and change the signal code.

- Confirm the setting of the remote control unit signal code and the printed circuit board setting. If these are not confirmed, the remote control unit cannot be used to operate for the air conditioner.

Table 11

DIP SWITCH		Remote control unit signal code
DIP3	DIP4	
OFF	OFF	A (Primary setting)
OFF	ON	B
ON	OFF	C
ON	ON	D

CUSTOMER GUIDANCE

Explain the following to the customer in accordance with the operating manual:

- Starting and stopping method, operation switching, temperature adjustment, timer, air flow switching, and other remote control unit operations.
- Air filter removal and cleaning, and how to use the air louvers.
- Give the operating manual and installation instruction sheet to the customer.
- If the signal code is changed, explain to the customer how it changed (the system returns to signal code A when the batteries in the remote control unit are replaced).